

Datasheet

AP6275SDPR

IEEE 802.11ax/ac/a/b/g/n 2x2

WiFi with Bluetooth5.3 Combo Sip Module

CONTENTS

1. Introduction	3
1.1 Product Overview	3
1.2 Product Features	3
1.2.1 WLAN.....	3
1.2.2 Bluetooth	3
2. Specification	4
2.1 General Specification.....	4
2.2 WiFi 2.4GHz RF Specification	5
2.3 WiFi 5GHz RF Specification.....	6
2.4 Bluetooth RFSpecification	10
3. Electrical Characteristics	11
3.1 Absolute Maximum Ratings.....	11
3.2 Recommended Operating Rating	11
4. Host Interface Timing Diagram	12
4.1 Power-up Sequence Timing Diagram	12
4.2 PCIe Interface Description	14
4.3 WLAN/PCIe Power-up timing	16
4.4 PCM Interface Description.....	17
Short Frame Sync, Slave Mode	18
4.5 UART Interface Description	22
5. Block Diagram.....	23
6. Pin Definition.....	24
6.1 Pin Outline	24
6.2 Pin Table	24
7. Mechanical Specifications.....	28
7.1 Module Dimensions.....	28
7.2 PCB Footprint	29
8. External clock reference	30
9. Recommended Reflow Profile	31
9.1 Caution for SMT Preparation.....	32
10. Package Information.....	33
11. Ordering Information	36

1. Introduction

1.1 Product Overview

AP6275SDPR is an 802.11ax (WiFi 6) SiP Module, 802.11ax allow Increased capacity, faster speed, better coverage connections, improve the battery life of IoT sensors, and extend the range of Wi-Fi signals. By implementing the new 802.11ax standard with its unique features such as OFDMA, 1024QAM, Target Wake Time (TWT), and spatial reuse, the AP6275SDPR module enables smooth streaming of high-resolution videos, fewer dropped connections and faster connections farther away from the router and in dense environments.

The Wi-Fi and Bluetooth 5.3 functionalities module with seamless roaming capabilities and advanced security. The 802.11 ax sip module can support Multi-User MIMO (MU-MIMO) technology to increase channel capacity when simultaneously servicing multiple devices using the same frequency chunks. Furthermore the included PCIe v3.0 interface for Wi-Fi, UART/ PCM interface for Bluetooth.

1.2 Product Features

1.2.1 WLAN

- Dual-stream spatial multiplexing up to 1200 Mbps data rate
- 20, 40, 80 MHz channels with optional SGI (1024 QAM modulation)
- TX and RX low-density parity check (LDPC) support for improved range and power efficiency
- Supports 2 antennas with two for shared BT and WLAN port
 - Supports PCI express revision 3.0 and power management running at Gen2 speeds
- Client MU-MIMO

1.2.2 Bluetooth

- BT host digital interface:
 - HCI UART (up to 4 Mbps)
 - PCM for audio data
- Complies with Bluetooth Core Specification Version 5.3 with provisions for supporting future specifications. With Bluetooth Class 1 or Class 2 transmitter operation
- Supports extended synchronous connections (eSCO), for enhanced voice quality by allowing for retransmission of dropped packets

2. Specification

2.1 General Specification

Standards	IEEE 802.11 ax/ac/a/b/g/n Wi-Fi + BT 5.1 Module(2T2R) Bluetooth : V5.3, V5.0, V4.2, V4.1, V4.0 LE, V3.0+HS, V2.1+EDR
Chipset	Broadcom
Operating Frequency	2.400 GHz ~ 2.4835 GHz (2.4GHz ISM Band) 5.150 GHz ~5.850GHz (5GHz UNII Band) Bluetooth: 2.402 GHz ~ 2.480 GHz
Modulation	WiFi: 802.11b: DSSS (DBPSK, DQPSK, CCK) 802.11g: OFDM (BPSK, QPSK, 16-QAM, 64-QAM) 802.11gn: OFDM (BPSK, QPSK, 16-QAM, 64-QAM) 802.11a: OFDM (BPSK, QPSK, 16-QAM, 64-QAM) 802.11an: OFDM (BPSK, QPSK, 16-QAM, 64-QAM) 802.11ac: OFDM (BPSK, QPSK, 16-QAM, 64-QAM, 256-QAM) 802.11ax: OFDMA (BPSK, QPSK, 16-QAM, 64-QAM, 256-QAM, 1024-QAM) BT: Header: GFSK Payload 2M: $\pi/4$ -DQPSK Payload 3M: 8-DPSK
WiFi Interface	Support PCIe v3.0 compliant and runs at Gen2 speeds.
BT Interface	UART / PCM
Form Factor	M.2 1216 Module
Antenna	2 x MHF4 connector
Dimension	L x W x H: 12mm(\pm 0.1mm) x 16mm(\pm 0.1mm) x 1.8mm(Max.)
Operating temperature	-40°C to 85°C
Storage temperature	-40°C to 125°C
Humidity(Non-Condensing)	10%~ 95% (Operating)
Weight	0.56g
Driver Support	Linux, Android

Note: The optimal RF performance specified in the data sheet, however, is guaranteed only -10 °C to +55 °C and 3.2V < VBAT < 3.6V without derating performance.

2.2 WiFi 2.4GHz RF Specification

Conditions: VBAT=3.3V; VDDIO=1.8V; Temp:25°C

Output Power, tolerance $\pm 1.5\text{dB}$					
The transmit EVM quality & spectrum mask are compliant with IEEE 802.11 standard					
802.11b	1Mbps	2Mbps	5.5Mbps	11Mbps	
	19	19	19	19.	
802.11g	6、9Mbps	12、18Mbps	24Mbps	36Mbps	48Mbps
	19	19	18.5	18.5	18
	54Mbps				
802.11n 20MHz	MCS0~2	MCS3	MCS4	MCS5	MCS6
	19	18.5	18.5	18	17
	MCS7				
802.11ax 20MHz	HE0~2	HE3	HE4	HE5	HE6
	19	18.5	18.5	18	17
	HE7	HE8	HE9		
	16.5	16	15.5		

Note: The specifications of RF output power are subject to change to fulfill the safety regulation and requirements in end-user product.

Sensitivity, tolerance $\pm 2\text{dB}$				
CCK modulation PER $\leq 8\%$ 、OFDM modulation PER $\leq 10\%$				
802.11b	Data Rate	Spec.(dBm)		
	1Mbps	-97		
	2Mbps	-93		
	5.5Mbps	-91		
	11Mbps	-89		
802.11g SISO	Data Rate	Spec.(dBm)	Data Rate	Spec.(dBm)
	6Mbps	-93	24Mbps	-85
	9Mbps	-92	36Mbps	-82
	12Mbps	-91	48Mbps	-78
	18Mbps	-88	54Mbps	-76
802.11g MIMO	Data Rate	Spec.(dBm)	Data Rate	Spec.(dBm)
	6Mbps	-95	24Mbps	-87
	9Mbps	-94	36Mbps	-84
	12Mbps	-93	48Mbps	-81
	18Mbps	-90	54Mbps	-78
802.11n_20MHz SISO	Data Rate	Spec.(dBm)	Data Rate	Spec.(dBm)
	MCS0	-92	MCS4	-81.5
	MCS1	-89	MCS5	-79
	MCS2	-87	MCS6	-76
	MCS3	-84	MCS7	-75
802.11n_20MHz MIMO	Data Rate	Spec.(dBm)	Data Rate	Spec.(dBm)
	MCS0	-93	MCS5	-80
	MCS1	-92	MCS6	-78
	MCS2	-90	MCS7	-76
	MCS3	-87	MCS8	-72
802.11ax_20MHz SISO	Data Rate	Spec.(dBm)	Data Rate	Spec.(dBm)
	MCS0	-93	MCS6	-76
	MCS1	-89	MCS7	-76

	MCS2	-87	MCS8	-72
	MCS3	-84	MCS9	-70
	MCS4	-81.5		
	MCS5	-79		
Maximum Input Level	802.11b : -10 dBm			
	802.11g/n/ax : -20 dBm			

2.3 WiFi 5GHz RF Specification

Conditions: VBAT=3.3V; VDDIO=1.8V; Temp:25°C

Output Power, tolerance ± 2 dB					
The transmit EVM quality & spectrum mask are compliant with IEEE 802.11 standard					
802.11a	Frequency (MHz)	6~9Mbps	12~18Mbps	24Mbps	36Mbps
	5150~5350	16	16	15.5	15.5
	5470~5720	16	16	15.5	15.5
	5725~5845	16	16	15.5	15.5
	Frequency (MHz)	48Mbps	54Mbps		
	5150~5350	15.5	15		
	5470~5720	15.5	15		
802.11n 20MHz	Frequency (MHz)	MCS0~2	MCS3	MCS4	MCS5
	5150~5350	16	16	15.5	15.5
	5470~5720	16	16	15.5	15.5
	5725~5845	16	16	15.5	15.5
	Frequency (MHz)	MCS6	MCS7		
	5150~5350	15	14.5		
	5470~5720	15	14.5		
802.11n 40MHz	Frequency (MHz)	MCS0~2	MCS3	MCS4	MCS5
	5150~5350	15.5	15.5	15	15
	5470~5720	15.5	15.5	15	15
	5725~5845	15.5	15.5	15	15
	Frequency (MHz)	MCS6	MCS7		
	5150~5350	14.5	14		
	5470~5720	14.5	14		
802.11ac 20MHz	Frequency (MHz)	MCS0~2	MCS3	MCS4	MCS5
	5150~5350	16	16	15.5	15.5
	5470~5720	16	16	15.5	15.5
	5725~5845	16	16	15.5	15.5
	Frequency (MHz)	MCS6	MCS7	MCS8	
	5150~5350	15	14.5	12	
	5470~5720	15	14.5	12	
802.11ac 40MHz	Frequency (MHz)	MCS0~2	MCS3	MCS4	MCS5
	5150~5350	15.5	15.5	15	15
	5470~5720	15.5	15.5	15	15
	5725~5845	15.5	15.5	15	15
	Frequency (MHz)	MCS6	MCS7	MCS8	MCS9
	5150~5350	14.5	14	12	10
	5470~5720	14.5	14	12	10
5725~5845	14.5	14	12	10	

802.11ac 80MHz	Frequency (MHz)	MCS0~2	MCS3	MCS4	MCS5
	5150~5350	16	15	14.5	14.5
	5470~5720	16	15	14.5	14.5
	5725~5845	16	15	14.5	14.5
	Frequency (MHz)	MCS6	MCS7	MCS8	MCS9
	5150~5350	14	14	10	10
	5470~5720	14	14	10	10
	5725~5845	14	14	10	10
	802.11ax 20MHz	Frequency (MHz)	HE0~2	HE3	HE4
5150~5350		16	15.5	15.5	15.5
5470~5720		16	15.5	15.5	15.5
5725~5845		16	15.5	15.5	15.5
Frequency (MHz)		HE6	HE7	HE8	HE9
5150~5350		14.5	14.5	12	12
5470~5720		14.5	14.5	12	12
5725~5845		14.5	14.5	12	12
Frequency (MHz)		HE10	HE11		
5150~5350		10	10		
5470~5720		10	10		
5725~5845		10	10		
802.11ax 40MHz	Frequency (MHz)	HE0~2	HE3	HE4	HE5
	5150~5350	15.5	15.5	15	15
	5470~5720	15.5	15.5	15	15
	5725~5845	15.5	15.5	15	15
	Frequency (MHz)	HE6	HE7	HE8	HE9
	5150~5350	14.5	14	12	10
	5470~5720	14.5	14	12	10
	5725~5845	14.5	14	12	10
	Frequency (MHz)	HE10	HE11		
	5150~5350	8	8		
	5470~5720	8	8		
	5725~5845	8	8		
802.11ax 80MHz	Frequency (MHz)	HE0~2	HE3	HE4	HE5
	5150~5350	15.5	15	14.5	14.5
	5470~5720	15.5	15	14.5	14.5
	5725~5845	15.5	15	14.5	14.5
	Frequency (MHz)	HE6	HE7	HE8	HE9
	5150~5350	14	14	10	10
	5470~5720	14	14	10	10
	5725~5845	14	14	10	10
	Frequency (MHz)	HE10	HE11		
	5150~5350	8	8		
	5470~5720	8	8		
	5725~5845	8	8		

Note: The specifications of RF output power are subject to change to fulfill the safety regulation and requirements in end-user product.

Sensitivity, tolerance ± 2 dB
OFDM modulation PER $\leq 10\%$

802.11a SISO	Data Rate	Spec.(dBm)	Data Rate	Spec.(dBm)
	6Mbps	-90	24Mbps	-83
	9Mbps	-89	36Mbps	-80
	12Mbps	-88	48Mbps	-75
	18Mbps	-86	54Mbps	-73

802.11a MIMO	Data Rate	Spec.(dBm)	Data Rate	Spec.(dBm)
	6Mbps	-92	24Mbps	-86
	9Mbps	-91	36Mbps	-83
	12Mbps	-90	48Mbps	-78
	18Mbps	-89	54Mbps	-77
802.11n_20MHz SISO	Data Rate	Spec.(dBm)	Data Rate	Spec.(dBm)
	MCS0	-90	MCS4	-79
	MCS1	-88	MCS5	-76
	MCS2	-86	MCS6	-73
	MCS3	-83	MCS7	-72
802.11n_20MHz MIMO	Data Rate	Spec.(dBm)	Data Rate	Spec.(dBm)
	MCS0	-92	MCS5	-78
	MCS1	-91	MCS6	-76
	MCS2	-89	MCS7	-74
	MCS3	-86	MCS8	-89
	MCS4	-82	MCS15	-70
802.11n_40MHz SISO	Data Rate	Spec.(dBm)	Data Rate	Spec.(dBm)
	MCS0	-88	MCS4	-77
	MCS1	-86	MCS5	-72
	MCS2	-83	MCS6	-70
	MCS3	-80	MCS7	-68
802.11n_40MHz MIMO	Data Rate	Spec.(dBm)	Data Rate	Spec.(dBm)
	MCS0	-88	MCS5	-75
	MCS1	-88	MCS6	-73
	MCS2	-86	MCS7	-71
	MCS3	-83	MCS8	-86
	MCS4	-79	MCS15	-67
802.11ac_20MHz SISO	Data Rate	Spec.(dBm)	Data Rate	Spec.(dBm)
	MCS0	-90	MCS5	-75
	MCS1	-88	MCS6	-73
	MCS2	-86	MCS7	-70
	MCS3	-83	MCS8	-68
	MCS4	-79		
802.11ac_20MHz MIMO	Data Rate	Spec.(dBm)	Data Rate	Spec.(dBm)
	MCS0,NSS=1	-92	MCS6,NSS=1	-76
	MCS1,NSS=1	-91	MCS7,NSS=1	-75
	MCS2,NSS=1	-88	MCS8,NSS=1	-72
	MCS3,NSS=1	-85	MCS0,NSS=2	-88
	MCS4,NSS=1	-82	MCS8,NSS=2	-65
802.11ac_40MHz SISO	Data Rate	Spec.(dBm)	Data Rate	Spec.(dBm)
	MCS0	-88	MCS5	-72
	MCS1	-86	MCS6	-70
	MCS2	-83	MCS7	-69
	MCS3	-80	MCS8	-65
	MCS4	-76	MCS9	-64
802.11ac_40MHz MIMO	Data Rate	Spec.(dBm)	Data Rate	Spec.(dBm)
	MCS0,NSS=1	-90	MCS6,NSS=1	-73
	MCS1,NSS=1	-88	MCS7,NSS=1	-72
	MCS2,NSS=1	-86	MCS8,NSS=1	-68
	MCS3,NSS=1	-82	MCS9,NSS=1	-66
	MCS4,NSS=1	-79	MCS0,NSS=2	-86
	MCS5,NSS=1	-77	MCS9,NSS=2	-60

802.11ac_80MHz SISO	Data Rate	Spec.(dBm)	Data Rate	Spec.(dBm)
	MCS0	-85	MCS5	-68
	MCS1	-82	MCS6	-67
	MCS2	-79	MCS7	-65
	MCS3	-76	MCS8	-62
	MCS4	-73	MCS9	-61
802.11ac_80MHz MIMO	Data Rate	Spec.(dBm)	Data Rate	Spec.(dBm)
	MCS0,NSS=1	-87	MCS6,NSS=1	-70
	MCS1,NSS=1	-85	MCS7,NSS=1	-68
	MCS2,NSS=1	-82	MCS8,NSS=1	-66
	MCS3,NSS=1	-79	MCS9,NSS=1	-63
	MCS4,NSS=1	-76	MCS0,NSS=2	-83
	MCS5,NSS=1	-71	MCS9,NSS=2	-58
802.11ax_20MHz SISO	Data Rate	Spec.(dBm)	Data Rate	Spec.(dBm)
	HE0	-90	HE6	-73
	HE1	-88	HE7	-70
	HE2	-86	HE8	-68
	HE3	-83	HE9	-64
	HE4	-79	HE10	-59
802.11ax_40MHz SISO	Data Rate	Spec.(dBm)	Data Rate	Spec.(dBm)
	HE0	-88	HE6	-70
	HE1	-86	HE7	-69
	HE2	-83	HE8	-65
	HE3	-80	HE9	-64
	HE4	-76	HE10	-60
802.11ax_80MHz SISO	Data Rate	Spec.(dBm)	Data Rate	Spec.(dBm)
	HE0	-85	HE6	-67
	HE1	-82	HE7	-65
	HE2	-79	HE8	-62
	HE3	-76	HE9	-61
	HE4	-73	HE10	-55
Maximum Input Level	HE5	-68	HE11	-51
	802.11a/n/ac/ax: -30 dBm			

2.4 Bluetooth RF Specification

Conditions: VBAT=3.3v ; VDDIO=1.8V ; Temp:25°C

RF Specification	
Output Power, tolerance ± 2 dB	
	CL1 (dBm)
BDR Output Power	7
EDR Output Power	5
BLE Output Power	7
Sensitivity, tolerance ± 2 dB	
Sensitivity @ BER=0.1% for GFSK (1Mbps)	-89 dBm
Sensitivity @ BER=0.01% for $\pi/4$ -DQPSK (2Mbps)	-92 dBm
Sensitivity @ BER=0.01% for 8DPSK (3Mbps)	-84 dBm
Sensitivity @ BER=30.8% for LE (1Mbps)	-92 dBm
Sensitivity @ BER=30.8% for 2LE (2Mbps)	-91 dBm
Maximum Input Level	GFSK (1Mbps): -20dBm
	$\pi/4$ -DQPSK (2Mbps): -20dBm
	8DPSK (3Mbps): -20dBm

Note* : The Bluetooth BDR output power is able to be configured by firmware (hcd file).

3. Electrical Characteristics

3.1 Absolute Maximum Ratings

Symbol	Description	Min.	Max.	Unit
VBAT	Input supply Voltage	-0.5	4.5	V
VDDIO	Digital/Bluetooth/I/O Voltage	-0.5	2.07	V

3.2 Recommended Operating Rating

The module requires two power supplies: VBAT and VDDIO.

Voltage rails	Min.	Typ.	Max.	Unit
VBAT	3.0	3.3	3.8	V
VDDIO	1.68	1.8	1.98	V

VBAT current consumption 1200mA (Peak), when VBAT = 3.3V

The module requires two power supplies: other Digital I/O Pins.

For VDDIO=1.8V	Min.	Max.	Unit
VIH	$0.65 \times VDDIO$	N/A	V
VIL	N/A	$0.4 \times VDDIO$	V
VOH output@2mA	$VDDIO - 0.4$	N/A	V
VOL output@2mA	N/A	0.4	V

4. Host Interface Timing Diagram

4.1 Power-up Sequence Timing Diagram

The module has signals that allow the host to control power consumption by enabling or disabling the Bluetooth, WLAN and internal regulator blocks. These signals are described below. Additionally, diagrams are provided to indicate proper sequencing of the signals for various operating states. The timing values indicated are minimum required values; longer delays are also acceptable.

- **WL_REG_ON:** This signal is used by the PMU to power up the WLAN section. It is also OR-gated with the BT_REG_ON input to control the internal regulators. When this pin is high, the regulators are enabled and the WLAN section is out of reset. When this pin is low, the WLAN section is in reset. If BT_REG_ON and WL_REG_ON are both low, the regulators are disabled.
- **BT_REG_ON:** This signal is used by the PMU to decide whether or not to power down the internal regulators. If BT_REG_ON and WL_REG_ON are low, the regulators will be disabled.
- It suggests customers connect WL_REG_ON and BT_REG_ON to GPIOs for control, otherwise unexpected errors may occur when boot-up the device.
- In the figure, The VDDIO power supply has been included in the module. When VBAT is power-up, VDDIO will rise to high level after 15 ms.
- The module main chip has an internal power-on reset (POR) circuit. The device will be held in reset for a maximum of 110 ms after VDDC and VDDIO have both passed the POR threshold. Wait at least 150 ms after VDDC and VDDIO are available before initiating PCIe accesses.

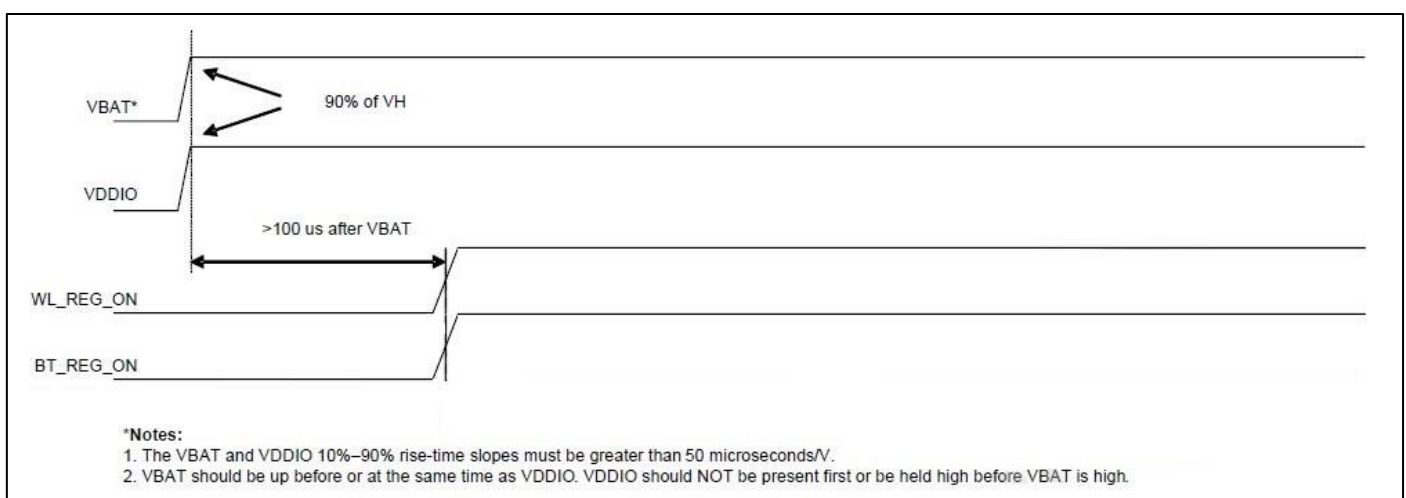

WLAN=ON, Bluetooth=ON

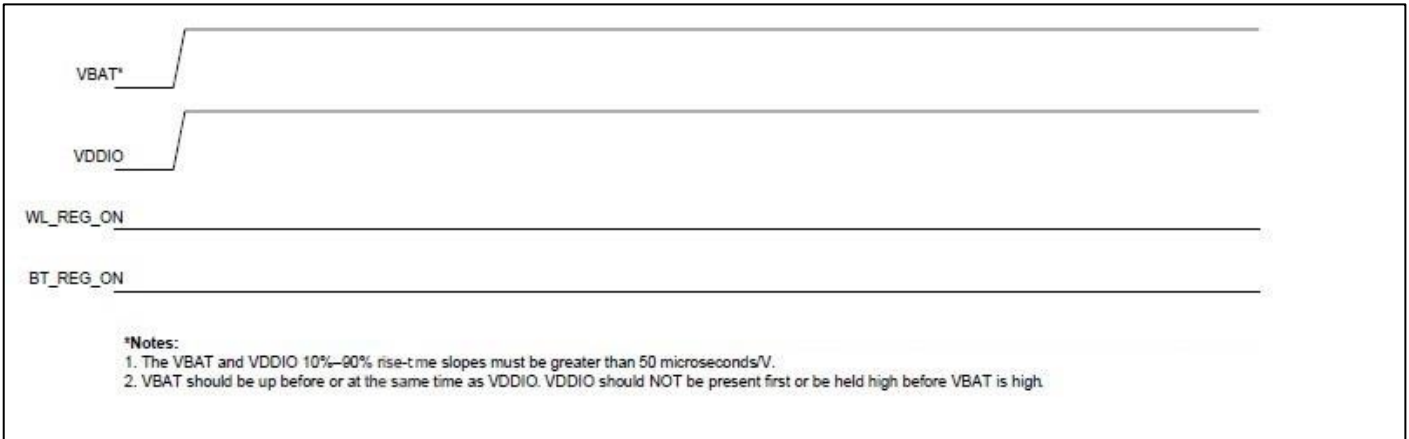

WLAN=OFF, Bluetooth=OFF

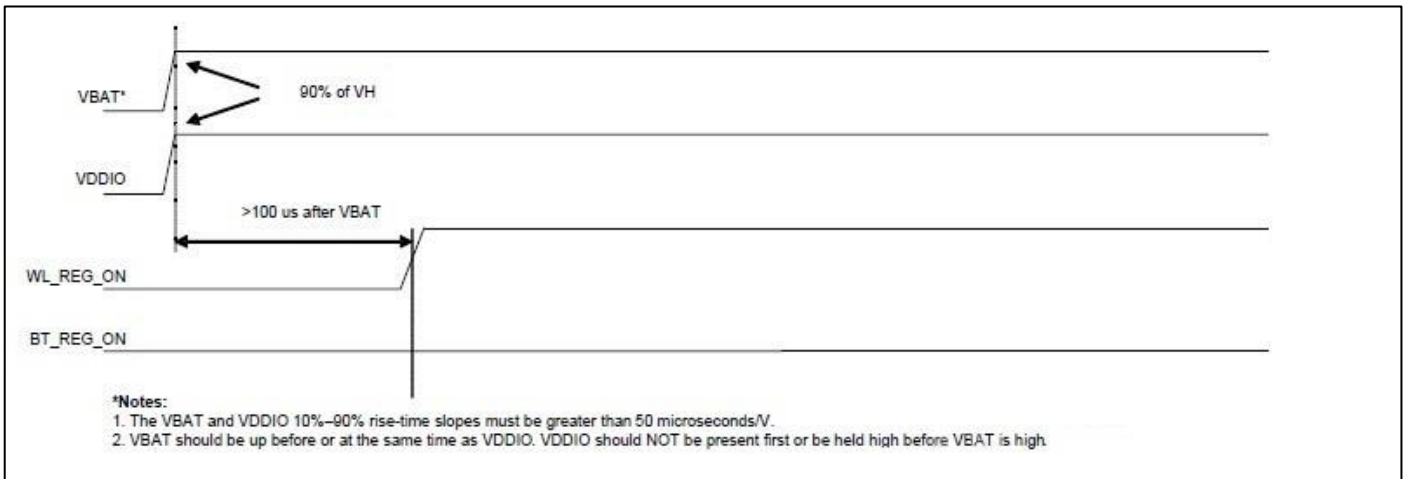

WLAN=ON, Bluetooth=OFF

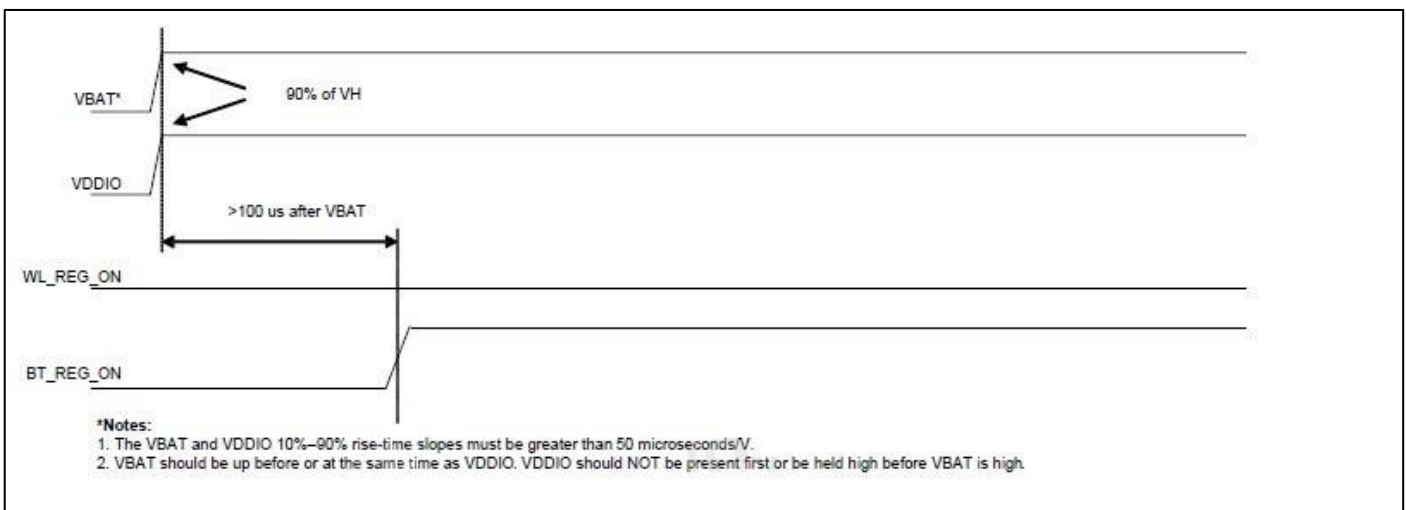

WLAN=OFF, Bluetooth=ON

4.2 PCIe Interface Description

The PCI Express (PCIe) core on the AP6275SDPR is a high-performance serial I/O interconnect that is protocol compliant and electrically compatible with the PCI Express Base Specification v3.0 running at Gen2 speeds.

PCI Express Interface Parameters

Parameter	Symbol	Comments	Min.	Typ.	Max.	Unit
General^a						
Baud rate	BPS	-	-	5	-	Gbaud
Reference clock peak -to-peak differential ^b	Vref	LVPECL, AC coupled	0.95	-	-	V
Receiver						
Differential termination	ZRX-DIFF-DC	Differential termination	80	100	120	Ω
DC impedance	ZRX-DC	DC common-mode impedance	40	50	60	Ω
Powered down termination (POS)	ZRX-HIGH-IMP-DC-POS	Powered down or RESET high impedance	100k	-	-	Ω
Powered down termination (NEG)	ZRX-HIGH-IMP-DC-NEG	Powered down or RESET high impedance	1k	-	-	Ω
Input voltage	VRX-DIFFp-p	AC coupled, differential p-p	175	-	-	mV
Jitter tolerance	TRX-EYE	Minimum receiver eye width	0.4	--	-	UI
Differential return loss	RLRX-DIFF	Differential return loss	10	-	-	dB
Common-mode return loss	RLRX-CM	Common-mode return loss	6	-	-	dB
Unexpected electrical idle enter detect threshold integration time	TRX-IDEL-DET-DIFF-ENTERTIME	An Unexpected electrical idle must be recognized no longer than this time to signal an unexpected idle condition	-	-	10	ms
Signal detect threshold	VRX-IDLE-DET-DIFFp-p	Electrical idle detect threshold	65	-	175	mV
Transmitter						
Output voltage	VTX-DIFFp-p	Differential p-p, programmable in 16 steps	0.8	-	1200	mV
Output voltage rise time	VTX-RISE	20% to 80%	0.125 (2.5 GT/s) 0.15 (5 GT/s)	-	-	UI
Output voltage fall time	VTX-FALL	80% to 20%	0.125 (2.5 GT/s) 0.15 (5 GT/s)	-	-	UI
RX detection voltage swing	VTX-RCV-DETECT	The amount of voltage change allowed during receiver detection	-	-	600	mV

PCI Express Interface Parameters (Continued)

Parameter	Symbol	Comments	Min.	Typ.	Max.	Unit
TX AC peak common-mode voltage (5 GT/s)	VTX-CM-AC-PP	TX AC common-mode voltage (5 GT/s)	-	-	100	mV
TX AC peak common-mode voltage (2.5 GT/s)	VTX-CM-AC-P	TX AC common-mode voltage (2.5 GT/s)	-	-	20	mV
Absolute delta of DC common-mode voltage during L0 and electrical idle	VTX-CM-DC-ACTIVE-DLE-DELTA	Absolute delta of DC common-mode voltage during L0 and electrical idle	0	-	100	mV
Absolute delta of DC common-mode voltage between D+ and D-	VTX-CM-DC-LINE-DELTA	DC offset between D+ and D-	0	-	25	mV
Electrical idle differential peak output voltage	VTX-IDLE-DIFF-AC-p	Peak-to-peak voltage	0	-	20	mV
TX short circuit current	ITX-SHORT	Current limit when TX output is shorted to ground	-	-	90	mA
DC differential TX termination	ZTX-DIFF-DC	Low impedance defined during signaling (parameter is captured for 5.0 GHz by RLTX-DIFF)	80	-	120	Ω
Differential return loss	RLTX-DIFF	Differential return loss	10 (min) for 0.05: 1.25 GHz	-	-	dB
Common-mode return loss	RLTX-CM	Common-mode return loss	6	-	-	dB
TX eye width	TTX-EYE	Minimum TX eye width	0.75	-	-	UI

4.3 WLAN/PCIe Power-up timing

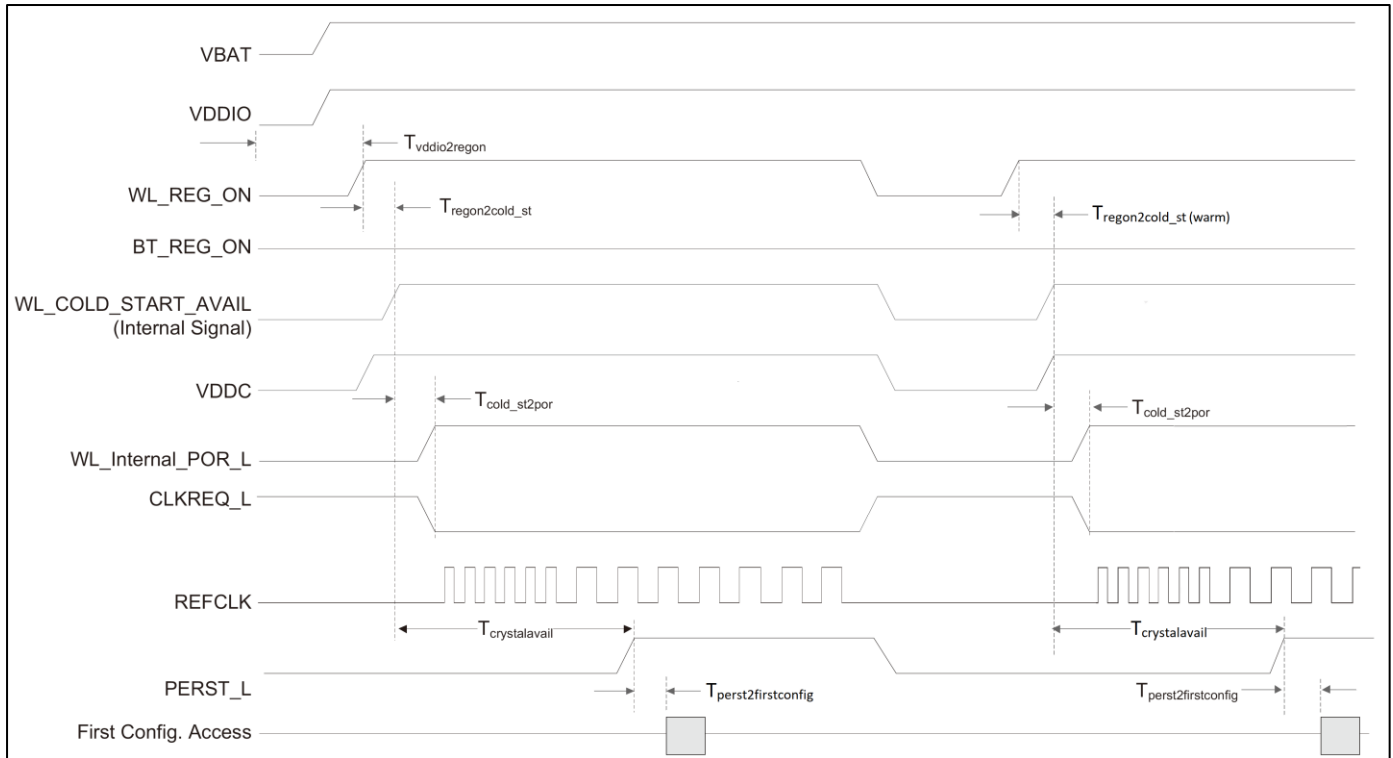

Timing Parameter	Notes	Value ^a	Unit
T _{vddio2regon}	-	0.1	ms
T _{regon2cold_st}	3.4ms+162 instruction-level parallelism(ILP) cycles	10.13	ms
T _{cold_st2por}	54 ILP cycles	2.24	ms
T _{crystalavail}	509 ILP cycles	21.17	ms
T _{perst2firstconfig}	-	6.0	ms
T _{vddioon2firstconfig}	T _{vddio2regon} +T _{regon2cold_st} +T _{crystalavail} +T _{perst2firstconfig}	37.4 ^b	ms
T _{regon2cold_st (warm)}	162 ILP cycles	6.73	ms

a. The times values assume an ILP tolerance of ±30%

b. With VDDIO as a reference, 37.4 ms is the minimum system wait time before issuing the first configuration access.

4.4 PCM Interface Description

AP6275SDPR supports two independent PCM interfaces that share the pins with the I²S interfaces. The PCM interface can connect to linear PCM codec devices in master or slave mode. In master mode, generates the BT_PCM_CLK and BT_PCM_SYNC signals, and in slave mode, these signals are provided by another master on the PCM interface and are inputs to the AP6275SDPR.

PCM Timing

Short Frame Sync, Master Mode

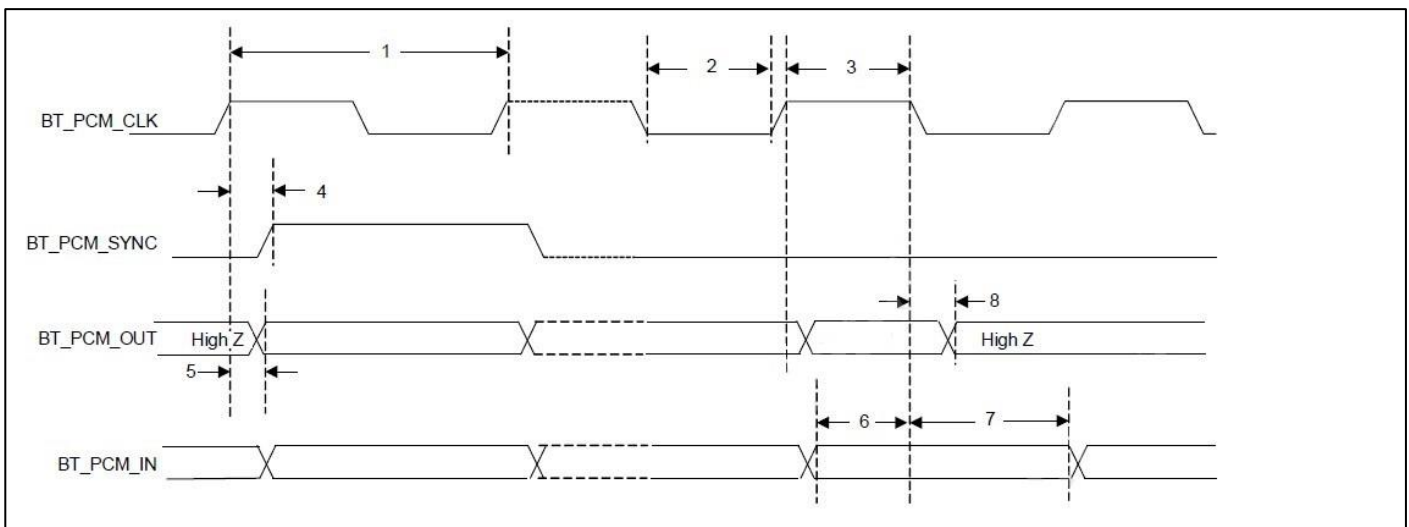

Reference	Characteristics	Minimum	Typical	Maximum	Unit
1	PCM bit clock frequency	-	-	12	MHz
2	PCM bit clock low	41	-	-	ns
3	PCM bit clock high	41	-	-	ns
4	BT_PCM_SYNC delay	0	-	25	ns
5	BT_PCM_OUT delay	0	-	25	ns
6	BT_PCM_IN setup	8	-	-	ns
7	BT_PCM_IN hold	8	-	-	ns
8	Delay from falling edge of BT_PCM_CLK during the last bit period to BT_PCM_OUT becoming high impedance.	0	-	25	ns

Short Frame Sync, Slave Mode

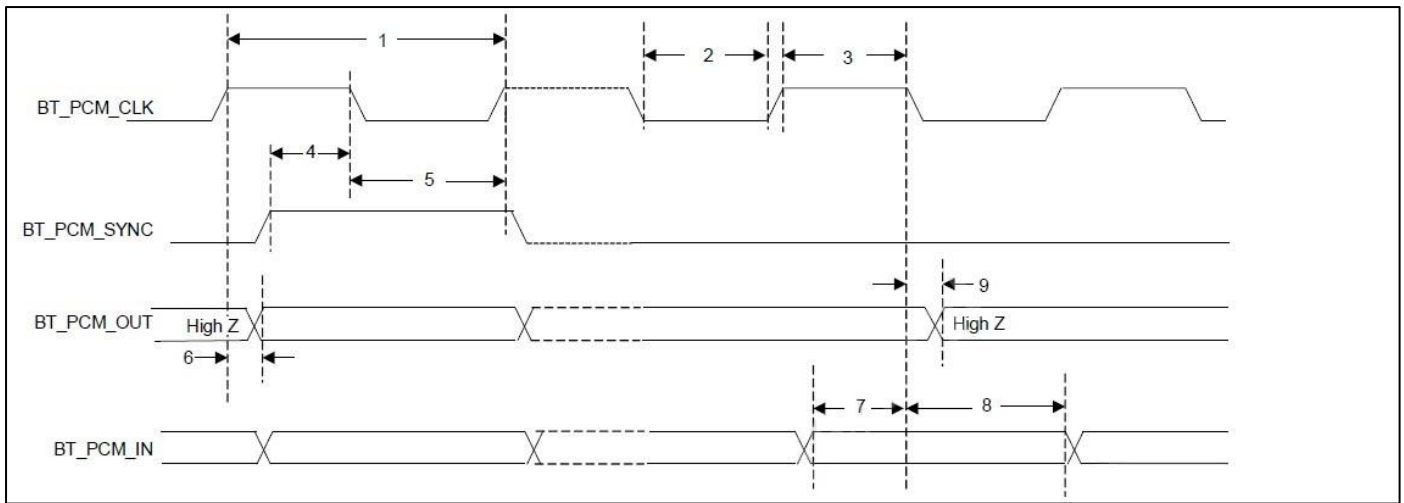

Reference	Characteristics	Minimum	Typical	Maximum	Unit
1	PCM bit clock frequency	-	-	12	MHz
2	PCM bit clock low	41	-	-	ns
3	PCM bit clock high	41	-	-	ns
4	BT_PCM_SYNC setup	8	-	-	ns
5	BT_PCM_SYNC hold	8	-	-	ns
6	BT_PCM_OUT delay	0	-	25	ns
7	BT_PCM_IN setup	8	-	-	ns
8	BT_PCM_IN hold	8	-	-	ns
9	Delay from falling edge of BT_PCM_CLK during the last bit period to BT_PCM_OUT becoming high impedance.	0	-	25	ns

Long Frame Sync, Master Mode

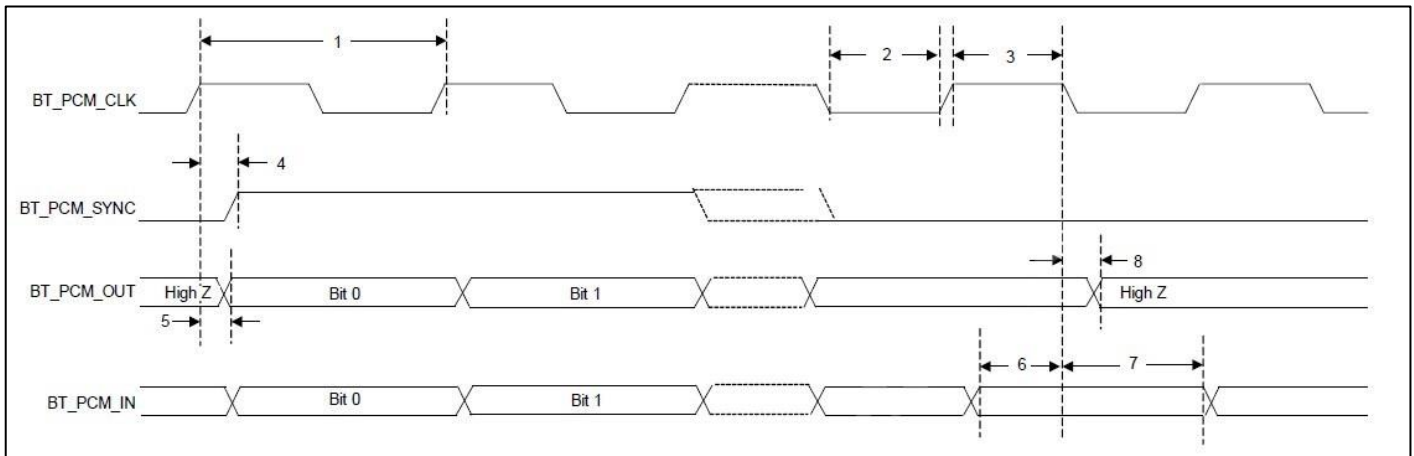

Reference	Characteristics	Minimum	Typical	Maximum	Unit
1	PCM bit clock frequency	-	-	12	MHz
2	PCM bit clock low	41	-	-	ns
3	PCM bit clock high	41	-	-	ns
4	BT_PCM_SYNC delay	0	-	25	ns
5	BT_PCM_OUT delay	0	-	25	ns
6	BT_PCM_IN setup	8	-	-	ns
7	BT_PCM_IN hold	8	-	-	ns
8	Delay from falling edge of BT_PCM_CLK during the last bit period to BT_PCM_OUT becoming high impedance.	0	-	25	ns

Long Frame Sync, Slave Mode

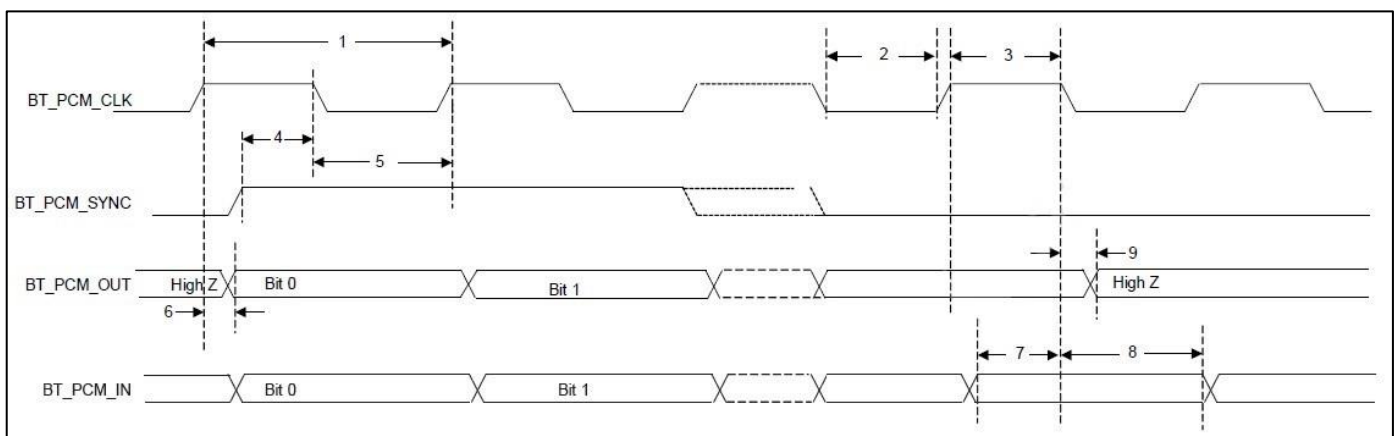

Reference	Characteristics	Minimum	Typical	Maximum	Unit
1	PCM bit clock frequency	-	-	12	MHz
2	PCM bit clock low	41	-	-	ns
3	PCM bit clock high	41	-	-	ns
4	BT_PCM_SYNC setup	8	-	-	ns
5	BT_PCM_SYNC hold	8	-	-	ns
6	BT_PCM_OUT delay	0	-	25	ns
7	BT_PCM_IN setup	8	-	-	ns
8	BT_PCM_IN hold	8	-	-	ns
9	Delay from falling edge of BT_PCM_CLK during the last bit period to BT_PCM_OUT becoming high impedance.	0	-	25	ns

Short Frame Sync, Burst Mod

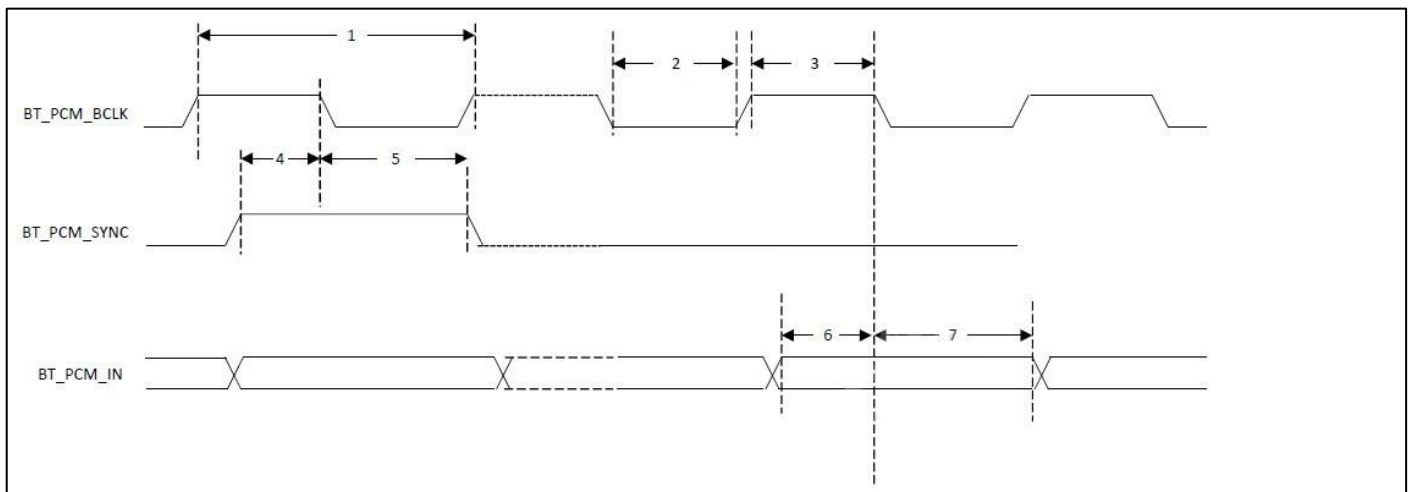

Reference	Characteristics	Minimum	Typical	Maximum	Unit
1	PCM bit clock frequency	-	-	24	MHz
2	PCM bit clock low	20.8	-	-	ns
3	PCM bit clock high	20.8	-	-	ns
4	BT_PCM_SYNC setup	8	-	-	ns
5	BT_PCM_OUT hold	8	-	-	ns
6	BT_PCM_IN setup	8	-	-	ns
7	BT_PCM_IN hold	8	-	-	ns

Long Frame Sync, Burst Mode

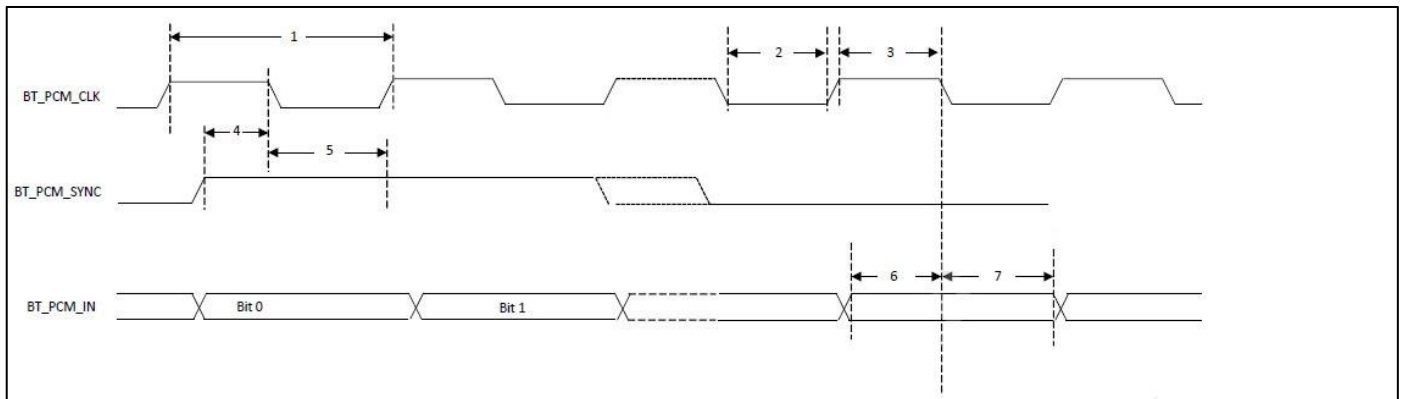

Reference	Characteristics	Minimum	Typical	Maximum	Unit
1	PCM bit clock frequency	-	-	24	MHz
2	PCM bit clock low	20.8	-	-	ns
3	PCM bit clock high	20.8	-	-	ns
4	BT_PCM_SYNC setup	8	-	-	ns
5	BT_PCM_SYNC hold	8	-	-	ns
6	BT_PCM_IN setup	8	-	-	ns
7	BT_PCM_IN hold	8	-	-	ns

4.5 UART Interface Description

The AP6275SDPR UART is a standard 4-wire interface with adjustable baud rates from 9600 bps to 4.0 Mbps. The interface features an automatic baud rate detection capability that returns a baud rate selection. Alternatively, the baud rate may be selected through a vendor-specific UART HCI command.

UART Timing

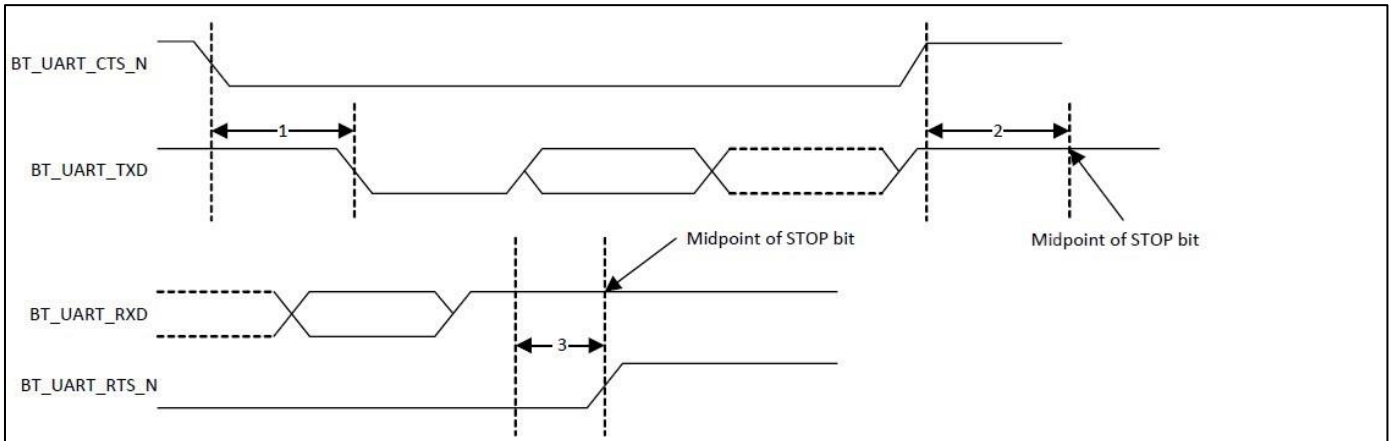

Reference	Characteristics	Minimum	Typical	Maximum	Unit
1	Delay time, BT_UART_CTS_N low to BT_UART_TZD valid	-	-	1.5	Bit periods
2	Setup time, BT_UART_CTS_N high before midpoint of stop bit	-	-	0.5	Bit periods
3	Setup time, midpoint of stop bit to BT_UART_RTS_N high	-	-	0.5	Bit periods

5. Block Diagram

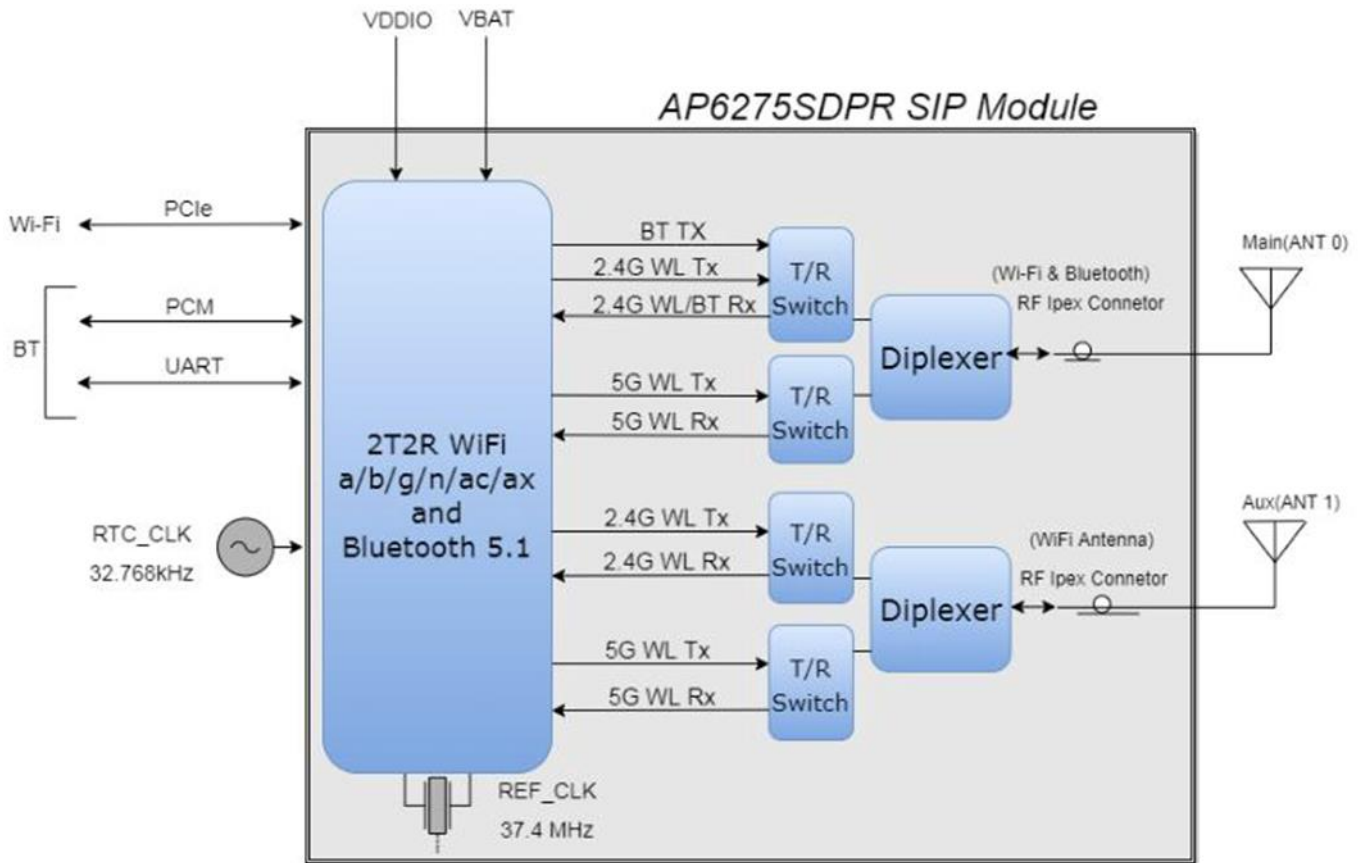

6. Pin Definition

6.1 Pin Outline

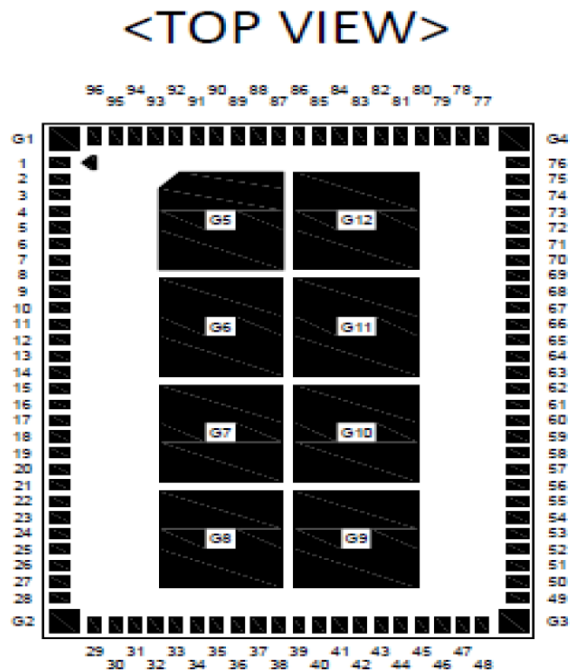

6.2 Pin Table

NO	Name	Type	Description
1	NC	—	Floating (Don't connected to ground)
2	NC	—	Floating (Don't connected to ground)
3	NC	—	Floating (Don't connected to ground)
4	VBAT	I	VBAT system power supply input
5	VBAT	I	VBAT system power supply input
6	GND	—	Ground connections
7	WL_GPIO5	I/O	WLAN GPIO 5
8	WL_GPIO8	I/O	WLAN GPIO 8
9	WL_GPIO9	I/O	WLAN GPIO 9
10	NC	—	Floating (Don't connected to ground)
11	NC	—	Floating (Don't connected to ground)
12	ABUCK_1P12	I	Internal Buck voltage generation pin
13	ABUCK_1P12	I	Internal Buck voltage generation pin
14	GND	—	Ground connections
15	ASR_VLX	O	Internal Analog Buck voltage generation pin

16	ASR_VLX	O	Internal Analog Buck voltage generation pin
17	GND	—	Ground connections
18	CSR_VLX	O	Internal Analog Buck voltage generation pin
19	CSR_VLX	O	Internal Analog Buck voltage generation pin
20	GND	—	Ground connections
21	CBUCK_OP9	I	Internal Buck voltage generation pin
22	CBUCK_OP9	I	Internal Buck voltage generation pin
23	GND	—	Ground connections
24	BT_WAKE	I	HOST wake-up Bluetooth device
25	NC	—	Floating (Don't connected to ground)
26	GND	—	Ground connections
27	LPO_IN	I	External Low Power Clock input (32.768KHz)
28	WL_GPIO1	I/O	WLAN GPIO 1/WL_DEV_WAKE
29	PCIE_PME_L	OD	PCI power management event output
30	PCIE_CLKREQ_L	OD	PCIe clock request
31	PCIE_PERST_L	I	PCIe host indication to reset the device
32	GND	—	Ground connections
33	PCIE_RCLK_N	I	PCI Express differential clock input-Negative
34	PCIE_RCLK_P	I	PCI Express differential clock input-Positive
35	GND	—	Ground connections
36	PCIE_TX_N	O	PCI Express receive data-Negative
37	PCIE_TX_P	O	PCI Express receive data-Positive
38	GND	—	Ground connections
39	PCIE_RX_N	I	PCI Express transmit data- Negative
40	PCIE_RX_P	I	PCI Express transmit data-Positive
41	GND	—	Ground connections
42	NC	—	Floating (Don't connected to ground)
43	NC	—	Floating (Don't connected to ground)
44	NC	—	Floating (Don't connected to ground)
45	WL_REG_ON	I	Low asserting reset for WiFi core
46	WL_HOST_WAKE	O	WLAN to wake-up HOST
47	NC	—	Floating (Don't connected to ground)
48	NC	—	Floating (Don't connected to ground)
49	NC	—	Floating (Don't connected to ground)
50	NC	—	Floating (Don't connected to ground)

51	NC	—	Floating (Don't connected to ground)
52	NC	—	Floating (Don't connected to ground)
53	BT_HOST_WAKE	O	Bluetooth device to wake-up HOST
54	BT_UART_CTS	I	Bluetooth UART clear to send
55	BT_UART_TX	O	Bluetooth UART serial data output
56	BT_UART_RX	I	Bluetooth UART serial data input
57	BT_UART_RTS	O	Bluetooth UART request to send
58	PCM_SYNC	I/O	PCM Sync; can be master (output) or slave (input)
59	PCM_IN	I	PCM data input
60	PCM_OUT	O	PCM Data output
61	PCM_CLK	I/O	PCM clock; can be master (output) or slave (input)
62	GND	—	Ground connections
63	BT_REG_ON	I	Low asserting reset for Bluetooth core
64	WL_GPIO1	I/O	WLAN GPIO 1
65	WL_GPIO2	I/O	WLAN GPIO 2
66	DBG_UART_RX/WL_GPIO10	I/O	DBG UART Tx , WLAN GPIO 10
67	DBG_UART_TX/WL_GPIO11	I/O	DBG UART Rx , WLAN GPIO 11
68	GND	—	Ground connections
69	WL_GPIO1	I/O	WLAN GPIO 1
70	WL_GPIO2	I/O	WLAN GPIO 2
71	GND	—	Ground connections
72	VIO	P	I/O 1.8 Voltage supply input
73	VIO	P	I/O 1.8 Voltage supply input
74	GND	—	Ground connections
75	GND	—	Ground connections
76	GND	—	Ground connections
77	GND	—	Ground connections
78	GND	—	Ground connections
79	GND	—	Ground connections
80	GND	—	Ground connections
81	GND	—	Ground connections
82	GND	—	Ground connections
83	GND	—	Ground connections
84	GND	—	Ground connections
85	GND	—	Ground connections

86	GND	—	Ground connections
87	GND	—	Ground connections
88	GND	—	Ground connections
89	GND	—	Ground connections
90	GND	—	Ground connections
91	GND	—	Ground connections
92	GND	—	Ground connections
93	GND	—	Ground connections
94	GND	—	Ground connections
95	GND	—	Ground connections
96	GND	—	Ground connections
G1	GND	—	Ground connections
G2	GND	—	Ground connections
G3	GND	—	Ground connections
G4	GND	—	Ground connections
G5	GND	—	Ground connections
G6	GND	—	Ground connections
G7	GND	—	Ground connections
G8	GND	—	Ground connections
G10	GND	—	Ground connections
G11	GND	—	Ground connections
G12	GND	—	Ground connections

7. Mechanical Specifications

7.1 Module Dimensions

< TOP VIEW >

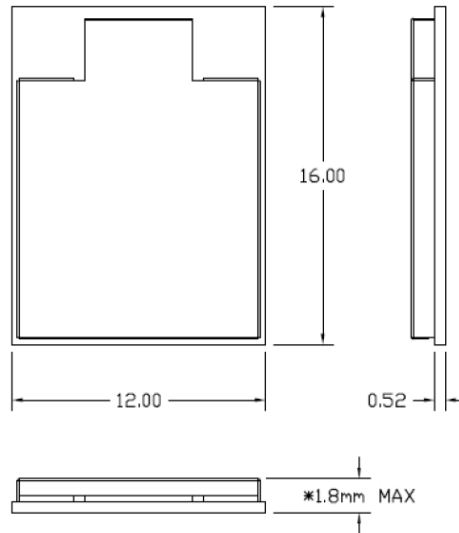

<TOP VIEW>

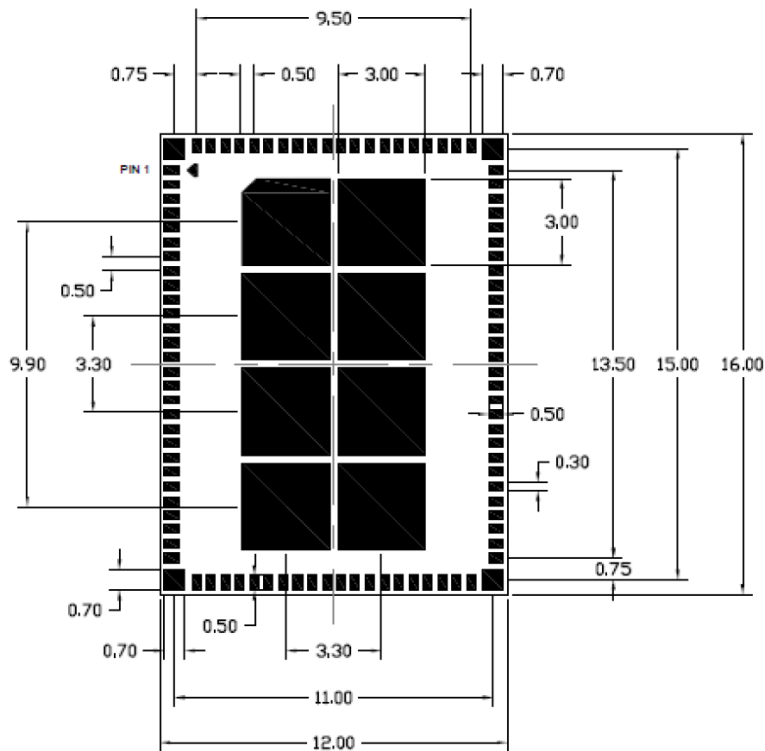

GENERAL TOLERANCE IS $\pm 0.10\text{mm}$
UNLESS OTHERWISE SPECIFIED

unit : mm

7.2 PCB Footprint

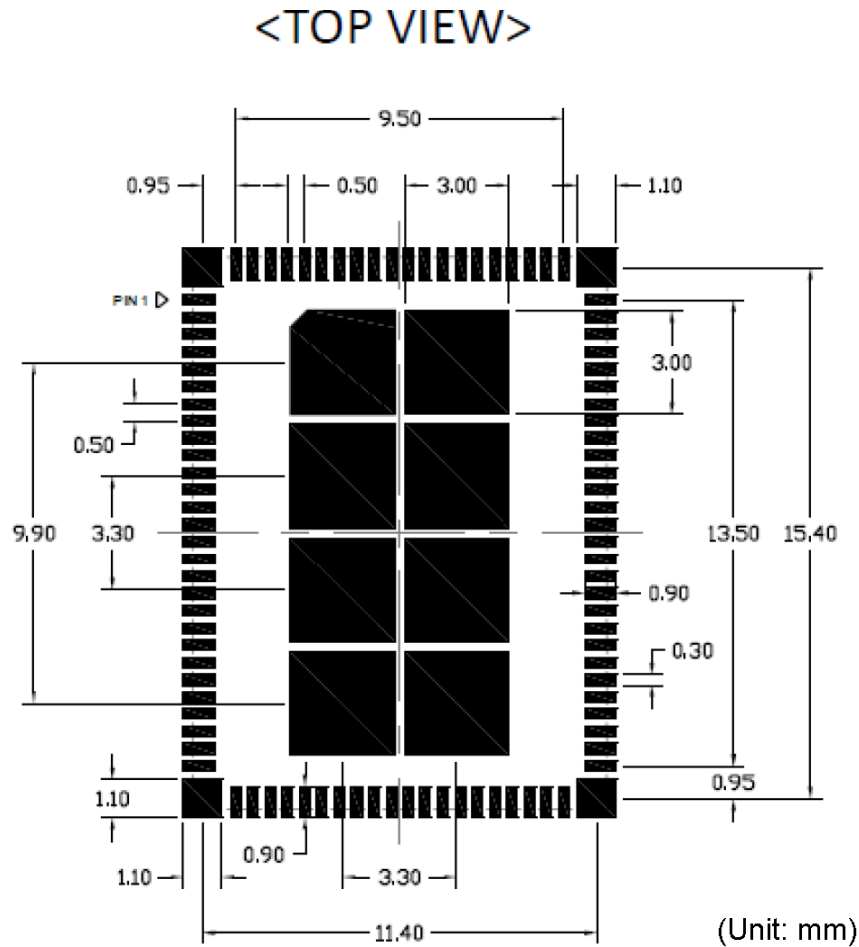

- Solder paste layer design is generally the same as recommended footprint.
(錫膏層設計通常建議和焊墊尺寸相同)
- If soldering quality with good wetting on upright side is essential for PQC, how to optimize the aperture design in the stencil to adjust the amount of solder paste would be crucial.

In addition, a kind of stencil design with stepped thickness in partial area would be considered if the thickness of stencil is about 0.1mm or thinner. Please optimize the stencil design by manufacture engineer or contact SparkLAN FAE for assistance.

(如果模組吃錫品質考量側面爬錫，如何優化鋼網開孔設計以調整適當的錫膏量是非常重要的，尤其鋼網的厚度大約是 0.1mm或更薄時，可考慮局部加厚鋼網的設計。請諮詢製程工程師以優化鋼網的設計,或是聯絡速連通訊技術支持團隊)。

8. External clock reference

External LPO signal characteristics

Parameter	Specification	Units
Nominal input frequency	32.768	kHz
Frequency accuracy	+/-25	ppm
Duty cycle	30 - 70	%
Input signal amplitude	1.8±0.09	V
Signal type	Square-wave or sine-wave	-
Input impedance	>100k <5	Ω pF
Clock jitter (integrated over 300Hz – 15KHz)	<1	Hz
Output high voltage	0.7V _{io} - V _{io}	V

9. Recommended Reflow Profile

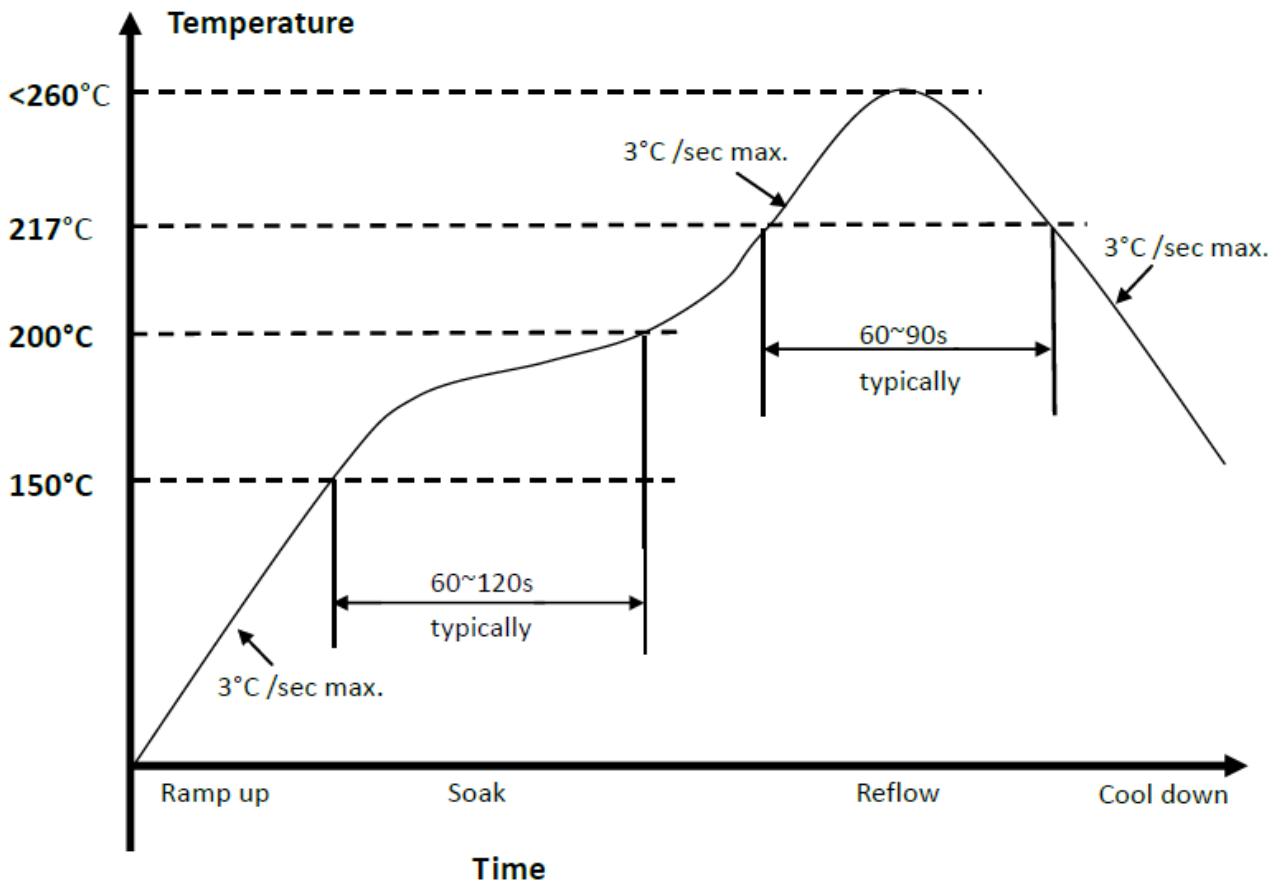

1. Referred to IPC/JEDEC standard
2. Peak Temperature: <260°C (Time within 5°C of actual Peak Temperature 20-40 seconds)
3. Cycle of Reflow: 2 times max.
4. Adding Nitrogen (N₂) to implement 2000ppm or less of oxygen concentration during reflow process is recommended.
5. If the shelf time is exceeded, be sure baking step to remove the moisture from the component

9.1 Caution for SMT Preparation

Moisture Sensitivity Level: 4

1. Calculated shelf life in sealed bag: 12 months at $<40^{\circ}\text{C}$ and $<90\%$ relative humidity (RH).
2. Peak package body temperature: 250°C .
3. After bag was opened, devices that will be subjected to reflow solder or other high temperature process must be
 - a) Mounted within: 72 hours of factory conditions $\leq 30^{\circ}\text{C}/60\%RH$ or
 - b) Stored per J-STD-033
4. Devices require bake before mounting, if:
 - a) Humidity Indicator Card reads $> 10\%$ for level 2a-5a devices or $>60\%$ for level 2 devices when read at $23\pm 5^{\circ}\text{C}$
 - b) 3a or 3b are not met.
5. If baking is required, refer to IPC/JEDEC J-STD-033 for bake procedure.

10. Package Information

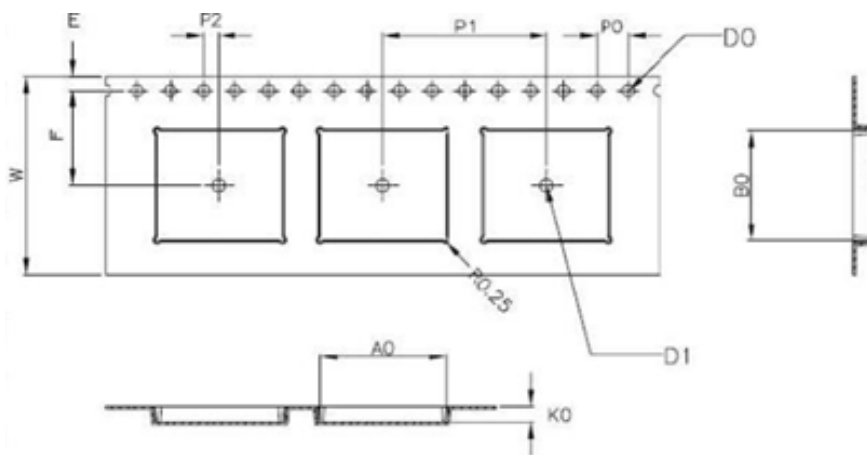
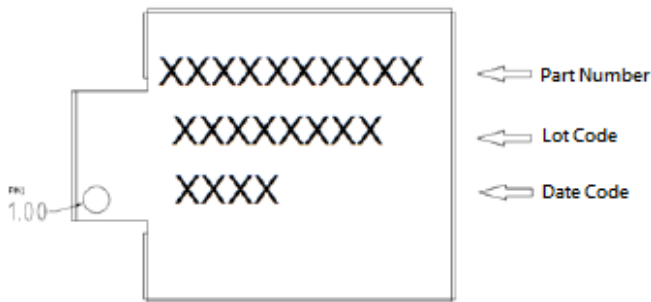

W	24.00±0.30
A0	15.30±0.10
B0	13.30±0.10
K0	2.00±0.10
E	1.75±0.10
F	11.50±0.10
P0	4.00±0.10
P1	20.00±0.10
P2	2.00±0.10
D0	1.50 ^{+0.10} _{-0.00}
D1	φ 1.50MIN

1. 10 sprocket hole pitch cumulative tolerance ±0.20.
2. Carrier camber is within 1 mm in 250 mm.
3. Material: Black Conductive Polystyrene Alloy.
4. All dimensions meet EIA-481-D requirements.
5. Thickness: 0.30±0.05mm.
6. Component load per 13" reel: 1000 pcs

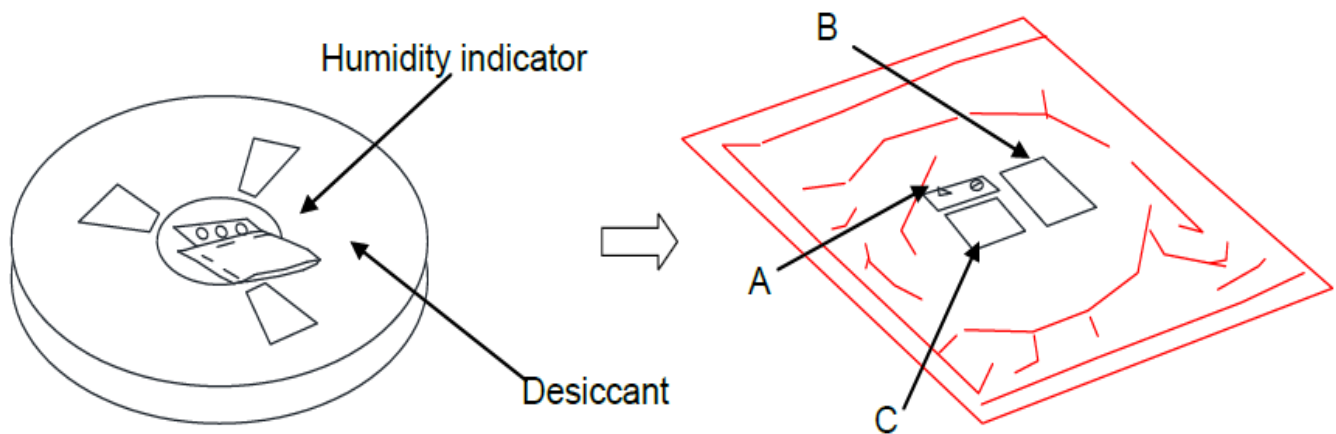
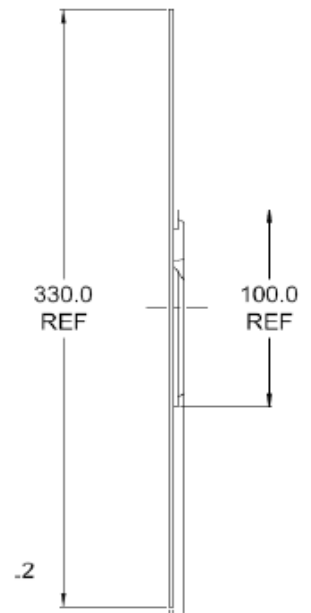
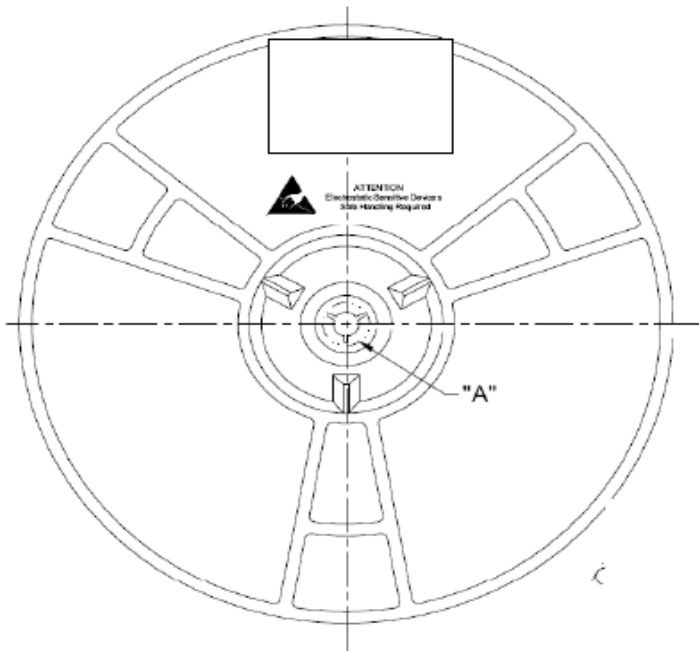

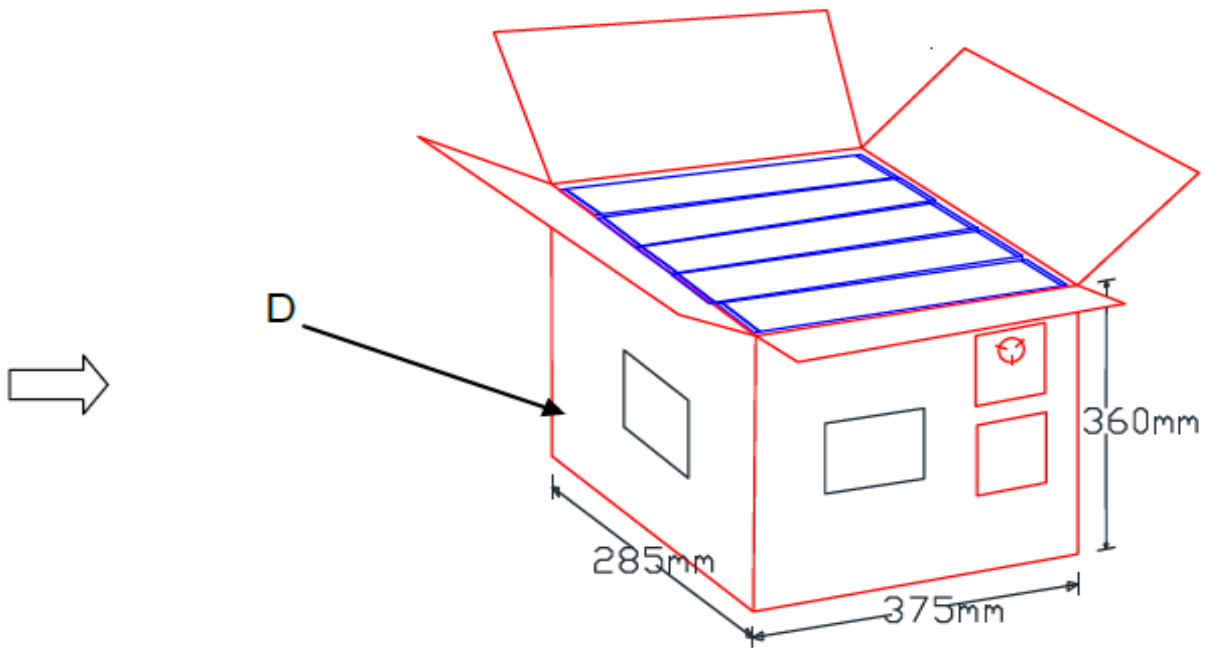
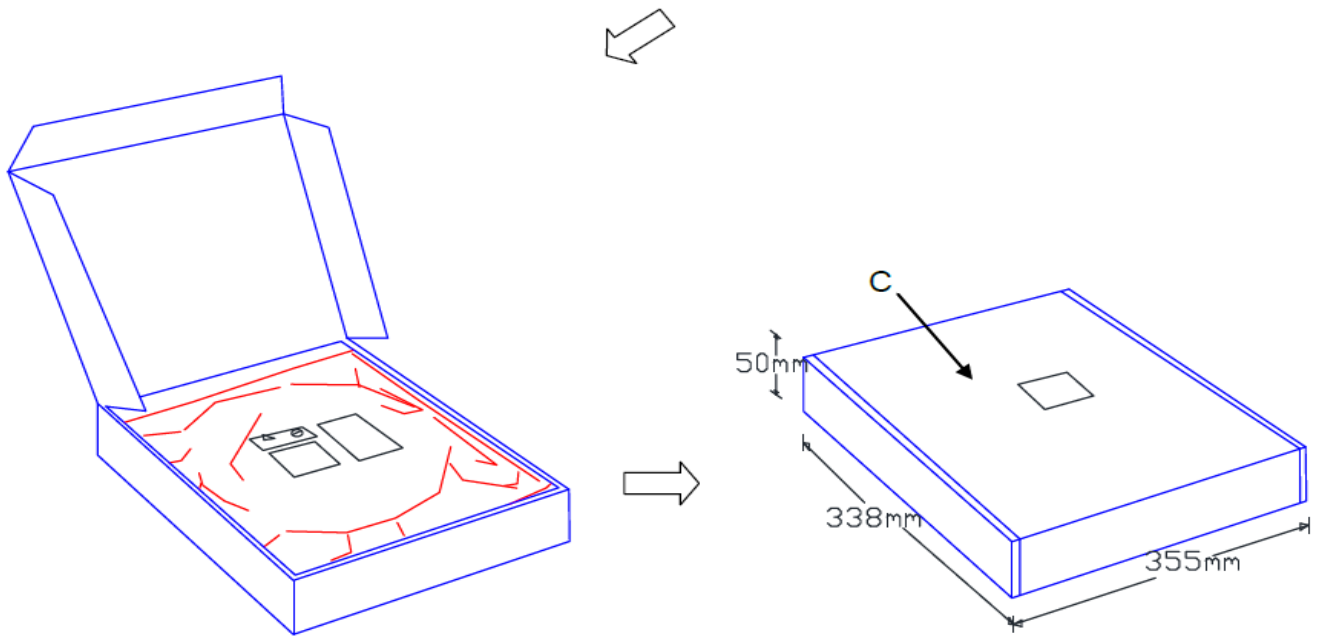

Note: 1 tape reel = 1 box = 1,000pcs
1 Carton = 5 box = 5,000pcs

11. Ordering Information

Product Name	Part Number	Description
AP6275SDPR	R9701A20004	11ax/ac/a/b/g/n 2T2R WiFi + BT5.3 Combo Sip Module