

WPEA-352ACNRBI

802.11ac/a/b/g/n Dual-Band

3T3R Industrial-Grade

Mini PCIe Module



Industrial Wi-Fi transceiver for Industrial Grade Solution

The WPEA-352ACNRBI is an industrial grade IEEE 802.11ac wireless adapter that operates in 2.4GHz and 5GHz bands, available in mini PCIe form factor. Featuring QCA9890 chipset, the operating temperature range is -40°C~+85°C. The WPEA-352ACNRBI dramatically increases the overall throughput up to 1.3Gbps with 3x3 MIMO technique. Leveraging the revolutionary 11ac technology, WPEA-352ACNRBI set a new benchmark in throughput and range, making it ideal for consumer and enterprise application.

The WPEA-352ACNRBI is powered by Qualcomm Atheros radio chip and features 3x3 802.11ac/a/b/g/n technology for higher throughput performance, reliability and range. It is reliable design for outdoor and rugged environments. High interference immunity for Wi-Fi congested environment and regulatory modular certifications to expedite system integration. It is reliable design for outdoor and rugged environments. High interference immunity for Wi-Fi congested environment and regulatory modular certifications to expedite system integration.

Embedded Application

Applications plication included outdoor Access point, Aviation, Vehicle-mount computer, Traffic controller, Factory Automation, Fleet management, Outdoor surveillance, Medical device, Industrial 4.0, etc.

Key Feature

- Industrial Temp Range: -40°C ~ +85°C
- Qualcomm Atheros QCA9890-BR4B
- Data Rates: allows link speeds up to 1.3Gbps
- Support Linux driver

Specification

Standards	IEEE 802.11ac/a/b/g/n (3T3R)
Chipset	Qualcomm Atheros QCA9890-BR4B
Data Rate	802.11b: 11Mbps 802.11a/g: 54Mbps 802.11n: 450Mbps 802.11ac: 1.3Gbps
Operating Frequency	IEEE 802.11ac/a/b/g/n ISM Band: 2.412GHz~2.484GHz, 5.150GHz~5.850GHz *Subject to local regulations
Interface	WLAN: PCIe
Form Factor	Mini PCIe
Antenna	3 x IPEX MHF1 connectors
Modulation	Wi-Fi: 802.11b: DSSS (DBPSK, DQPSK, CCK) 802.11g: OFDM (BPSK, QPSK, 16-QAM, 64-QAM) 802.11n: OFDM (BPSK, QPSK, 16-QAM, 64-QAM) 802.11a: OFDM (BPSK, QPSK, 16-QAM, 64-QAM) 802.11ac: OFDM (BPSK, QPSK, 16-QAM, 64-QAM, 256-QAM)
Power Consumption	TX mode: 1360mA (Max.) RX mode: 720mA (Max.)
Operating Voltage	DC 3.3V
Operating Temperature Range	-40°C~85°C
Storage Temperature Range	-40°C~85°C
Humidity (Non-Condensing)	10%~85% (Operating) 5%~90% (Storing)
Dimension L x W x H (in mm)	50.8mm(±0.3mm) x 29.85mm(±0.3mm) x 4.1mm(±0.3mm)
Weight (g)	7.7g
Driver Support	Linux
Security	64/128-bits WEP, WPA, WPA2, 802.1x

OUTPUT POWER & SENSITIVITY
802.11b

Data Rate	Tx \pm 2dBm	Rx Sensitivity
11Mbps	20dBm	\leq -86dBm

802.11g

Data Rate	Tx \pm 2dBm	Rx Sensitivity
54Mbps	16dBm	\leq -73dBm

802.11n / 2.4GHz

	Data Rate	Tx \pm 2dBm (1TX)	Tx \pm 2dBm (3TX)	Rx Sensitivity
HT20	MCS7	15dBm	19dBm	\leq -70dBm
HT40	MCS7	15dBm	19dBm	\leq -67dBm

802.11a

Data Rate	Tx \pm 2dBm	Rx Sensitivity
54Mbps	14dBm	\leq -73dBm

802.11n / 5GHz

	Data Rate	Tx \pm 2dBm (1TX)	Tx \pm 2dBm (3TX)	Rx Sensitivity
HT20	MCS7	13dBm	16dBm	\leq -71dBm
HT40	MCS7	13dBm	16dBm	\leq -68dBm

802.11ac

	Data Rate	Tx \pm 2dBm (1TX)	Tx \pm 2dBm (3TX)	Rx Sensitivity
VHT80	MCS9	10dBm	13dBm	\leq -58dBm

Block Diagram

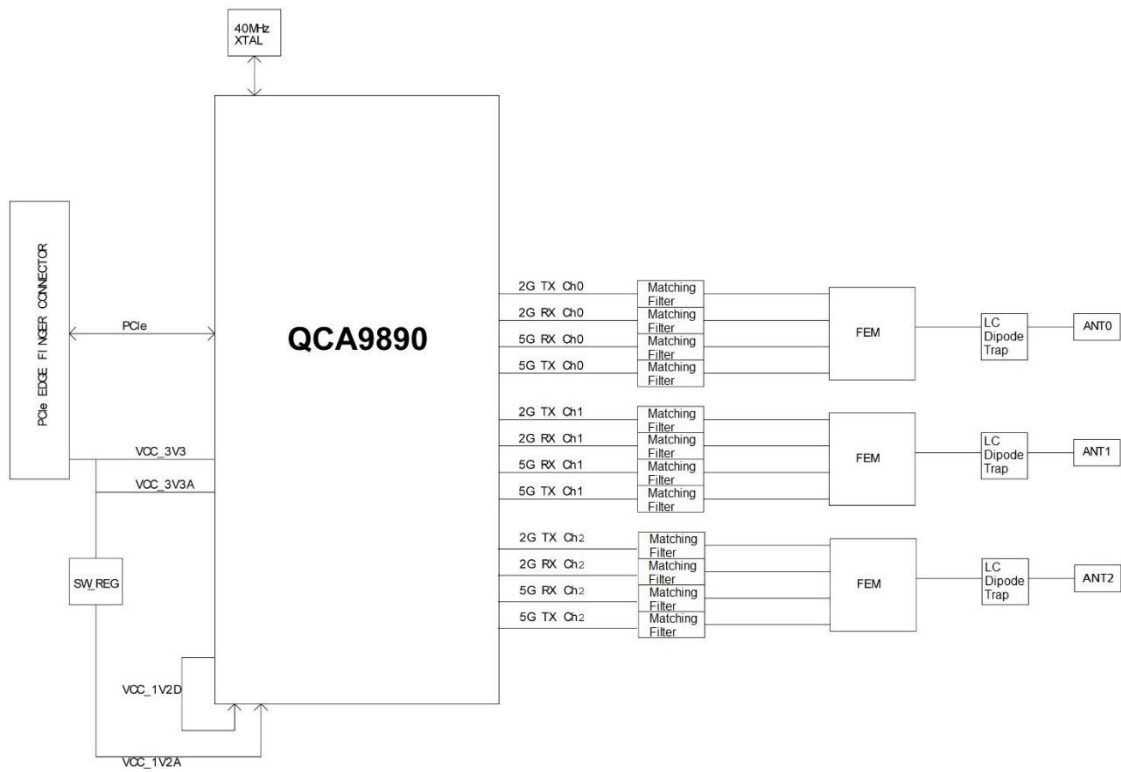

Mechanical Dimension (mm)

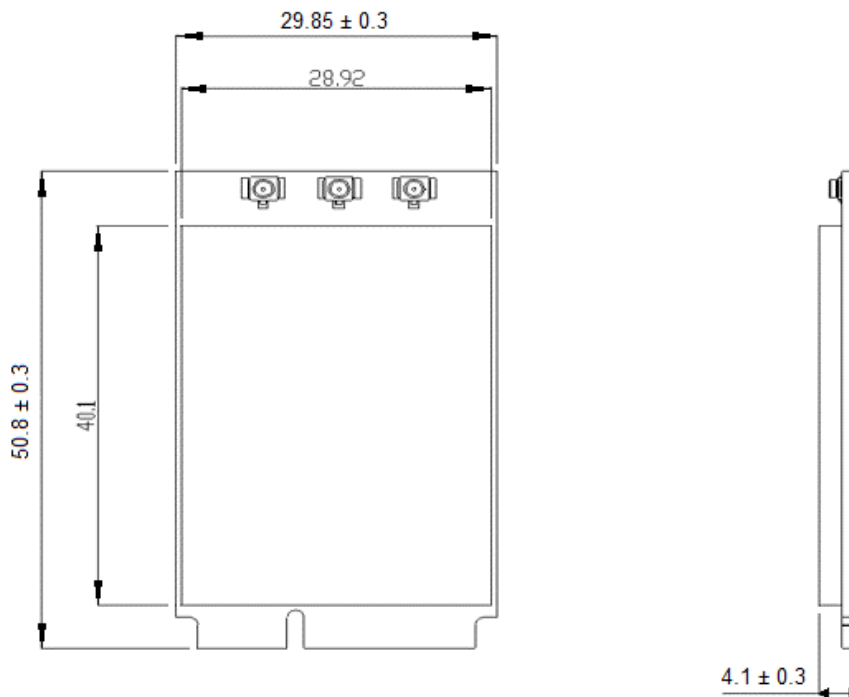

MHF1 connector spec.

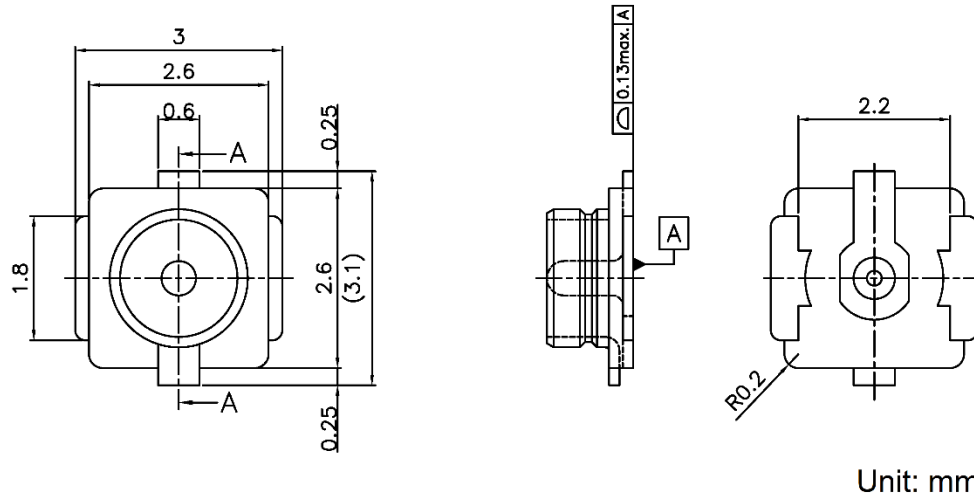

Pin Assignment

Pin#	Pin Name	Description	Pin#	Pin Name	Description
1	WAKE_L(NA)	Output and open Drain active Low signal. This signal is used to request that the system return from a sleep/ suspended state to service a function initiated wake event.	2	+3.3V	+3.3V
3	No Connection	-	4	GND	GND
5	No Connection	-	6	No Connection	-
7	CLKREQ_L	Output for reference clock request signal	8	No Connection	-
9	GND	GND	10	No Connection	-
11	REFCLK-	Input signal for PCI Express differential reference clock (100 MHz)	12	No Connection	-
13	REFCLK+	Input signal for PCI Express differential reference clock (100 MHz)	14	No Connection	-
15	GND	GND	16	No Connection	-
17	No Connection	-	18	GND	GND

Pin Assignment

Pin#	Pin Name	Description	Pin#	Pin Name	Description
19	No Connection	-	20	W_DISABLE_L (OPT)	Input and active low signal. This signal is used by the system to disable radio operation on add-in cards that implement radio frequency applications. When implemented, this signal requires a pull-up resistor on the card
21	GND	GND	22	PERST_L	Input signal for functional reset to the card
23	PERn0	PCI Express x1 data interface: one differential receive pair	24	+3.3V	+3.3V
25	PERp0	PCI Express x1 data interface: one differential receive pair	26	GND	GND
27	GND	GND	28	No Connection	-
29	GND	GND	30	No Connection	-
31	PETn0	PCI Express x1 data interface: one differential transmit pair	32	No Connection	-
33	PETp0	PCI Express x1 data interface: one differential transmit pair	34	GND	GND
35	GND	GND	36	No Connection	-
37	GND	GND	38	No Connection	-
39	No Connection	-	40	GND	GND
41	No Connection	-	42	No Connection	-
43	GND	GND	44	LED_WLAN_L (OPT)	Output and open drain active low signal. This signal is used to allow the PCI Express Mini Card add-in card to provide status indicators via LED devices that will be provided by the system.
45	No Connection	-	46	No Connection	-
47	No Connection	-	48	No Connection	-
49	No Connection	-	50	GND	GND
51	No Connection	-	52	+3.3V	+3.3V

*NA→No active

*OPT →Optional

Certification

Dipole Ant.

 FCC

 IC

 NCC

 CE (RED EN 300 328 V2.2.2 / EN 301 893 V2.1.1)

 MIC

 ASNZS

Ordering Information

Product Name	Part Number	Description
WPEA-352ACNRBI	R9701890023	802.11ac/b/g/n Mini PCIe module,3T3R Industrial Grade

Optional Accessory

Product Name	Part Number	Description
AD-103AG	R3410110203	Dipole Antenna, 2dBi 2.4GHz/5GHz, RP-SMA(M) connector
AD-300N	R3410110219	Antenna Dual -Band 2.4GHz/5GHz 3dBi/5dBi Omnidirectional RP-SMA PLUG(BSMA)
AD-301N	R3410110220	Dipole Antenna, 2.4G/5G 4.4dbi/5dbi RP-SMA(M) connector
AD-302N	R3410110221	Dipole Antenna, 3dBi/2dBi 2.4G/5GHz, RP-SMA(M) connector
AD-303N	R3410110222	Dipole Antenna, 3dBi/3dBi 2.4G/5GHz, RP-SMA(M) connector
AD-305N	R3410110223	Dipole Antenna, 5dBi/5dBi 2.4G/5GHz, RP-SMA(M) connector
CBIRF-ME150	R3470300023	I-PEX/MHF1 to RP-SMA Female; L:150mm; Coaxial 1.37 Black
CBIRF-ME250	R3470300024	I-PEX/MHF1 to RP-SMA Female; L:250mm; Coaxial 1.37 Black