

## WPEQ-256ACN

802.11ac/a/b/g/n Dual-Band

2T2R Mini PCIe Module



### High Performance Mini PCIe Module for Embedded Solution

The WPEQ-256ACN is powered by Qualcomm Atheros QCA9882 radio chip and features 2x2 11ac technology for higher throughput performance, reliability and range. It is designed to meet the demanding performance requirements of critical embedded applications.

The WPEQ-256ACN dramatically increase the overall throughput up to 867Mbps. Leveraging the revolutionary 11ac technology, WPEQ-256ACN sets a new benchmark in throughput and range, making it ideal for consumer and enterprise applications, such as point of sale, gaming machine and medical equipment.

#### Embedded Application

Applications include medical devices, security systems, industrial, Point of Sale, digital signs, industrial tablet PC's, handheld devices, thin client devices, Gaming machine, medical equipment, Robotic, warehouse, etc.

#### Key Feature

- Qualcomm Atheros QCA9882
- Antenna: 2 x IPEX MHF1 connector, 2T2R
- Data Rates: allows link speeds up to 867Mbps
- Support Linux driver
- 802.11ac compliant & backward compatible with 802.11a/b/g/n

**Specification**

<b>Standards</b>	IEEE 802.11ac/a/b/g/n (2T2R)
<b>Chipset</b>	Qualcomm Atheros QCA9882-BR4A
<b>Data Rate</b>	802.11b: 11Mbps 802.11a/g: 54Mbps 802.11n: 300Mbps 802.11ac: 867Mbps
<b>Operating Frequency</b>	IEEE 802.11ac/a/b/g/n ISM Band: 2.412GHz~2.484GHz, 5.150GHz~5.850GHz *Subject to local regulations
<b>Interface</b>	WLAN: PCIe
<b>Form Factor</b>	Mini PCIe
<b>Antenna</b>	2 x IPEX MHF1 connectors
<b>Modulation</b>	Wi-Fi: 802.11b: DSSS (DBPSK, DQPSK, CCK) 802.11g: OFDM (BPSK, QPSK, 16-QAM, 64-QAM) 802.11n: OFDM (BPSK, QPSK, 16-QAM, 64-QAM) 802.11a: OFDM (BPSK, QPSK, 16-QAM, 64-QAM) 802.11ac: OFDM (BPSK, QPSK, 16-QAM, 64-QAM, 256-QAM)
<b>Power Consumption</b>	TX mode: 1050mA (Max) RX mode: 480mA (Max)
<b>Operating Voltage</b>	DC 3.3V
<b>Operating Temperature Range</b>	-20°C~60°C
<b>Storage Temperature Range</b>	-30°C~75°C
<b>Humidity (Non-Condensing)</b>	10%~85% (Operating) 5%~90% (Storing)
<b>Dimension L x W x H (in mm)</b>	50.8mm(±0.3mm) x 29.85mm(±0.3mm) x 4.1mm(±0.3mm)
<b>Weight (g)</b>	7.8g
<b>Driver Support</b>	Linux
<b>Security</b>	64/128-bits WEP, WPA, WPA2, 802.1X

**OUTPUT POWER & SENSITIVITY**
**802.11b**

Data Rate	Tx $\pm$ 2dBm	Rx Sensitivity
11Mbps	20dBm	$\leq$ -87dBm

**802.11g**

Data Rate	Tx $\pm$ 2dBm	Rx Sensitivity
54Mbps	16dBm	$\leq$ -74dBm

**802.11n / 2.4GHz**

	Data Rate	Tx $\pm$ 2dBm (1TX)	Tx $\pm$ 2dBm (2TX)	Rx Sensitivity
HT20	MCS7	15dBm	18dBm	$\leq$ -70dBm
	MCS7	15dBm	18dBm	$\leq$ -68dBm

**802.11a**

Data Rate	Tx $\pm$ 2dBm	Rx Sensitivity
54Mbps	14dBm	$\leq$ -74dBm

**802.11n / 5GHz**

	Data Rate	Tx $\pm$ 2dBm (1TX)	Tx $\pm$ 2dBm (2TX)	Rx Sensitivity
HT20	MCS7	13dBm	16dBm	$\leq$ -71dBm
	MCS7	13dBm	16dBm	$\leq$ -68dBm

**802.11ac**

	Data Rate	Tx $\pm$ 2dBm (1TX)	Tx $\pm$ 2dBm (2TX)	Rx Sensitivity
VHT80	MCS9	10dBm	13dBm	$\leq$ -59dBm

**Block Diagram**

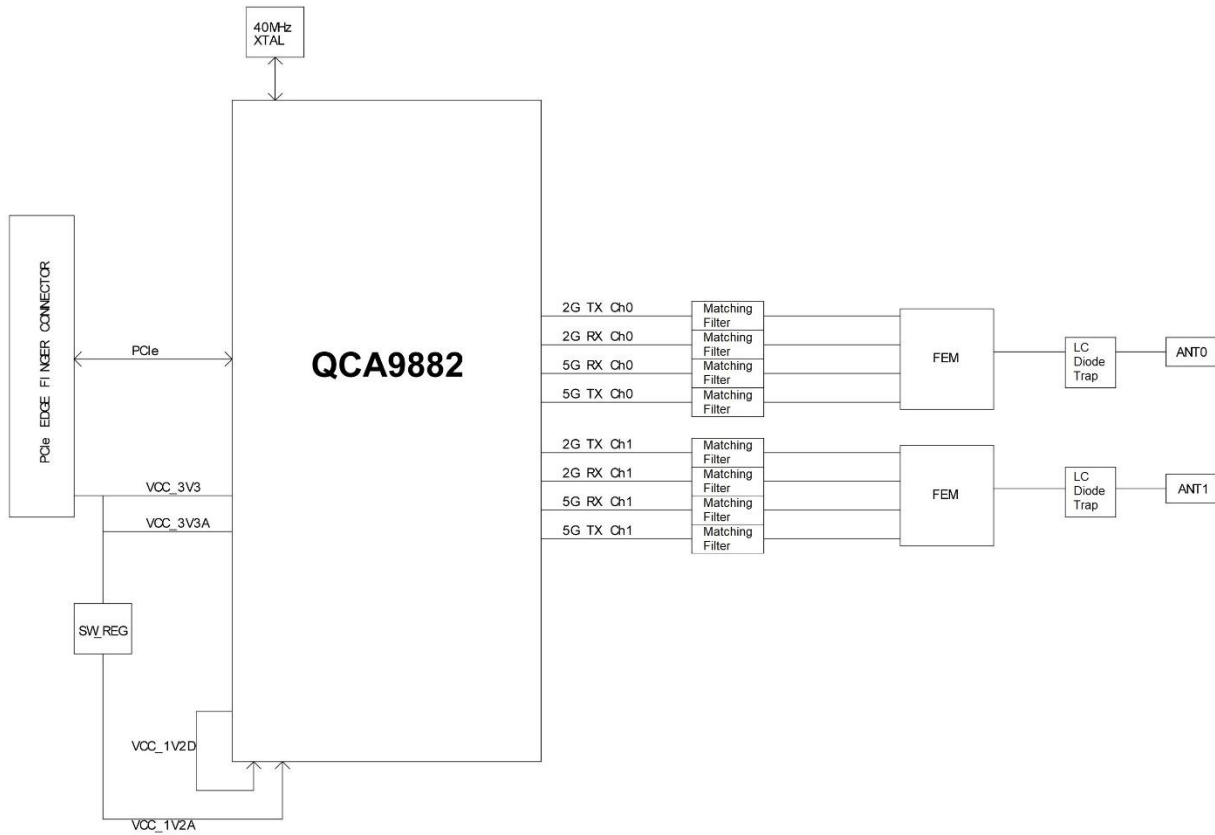

**Mechanical Diagram (mm)**

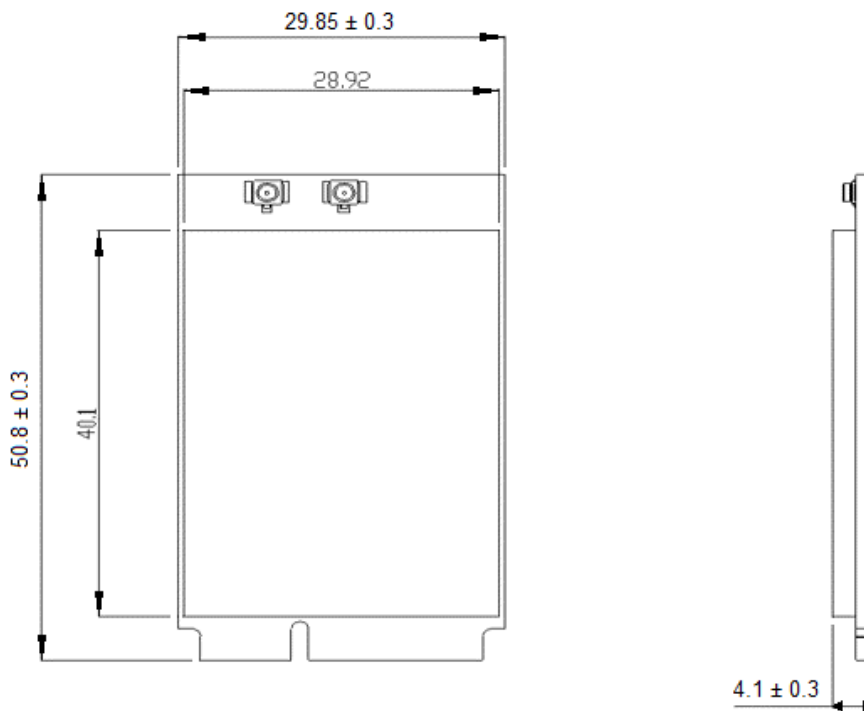

**MHF1 connector spec.**

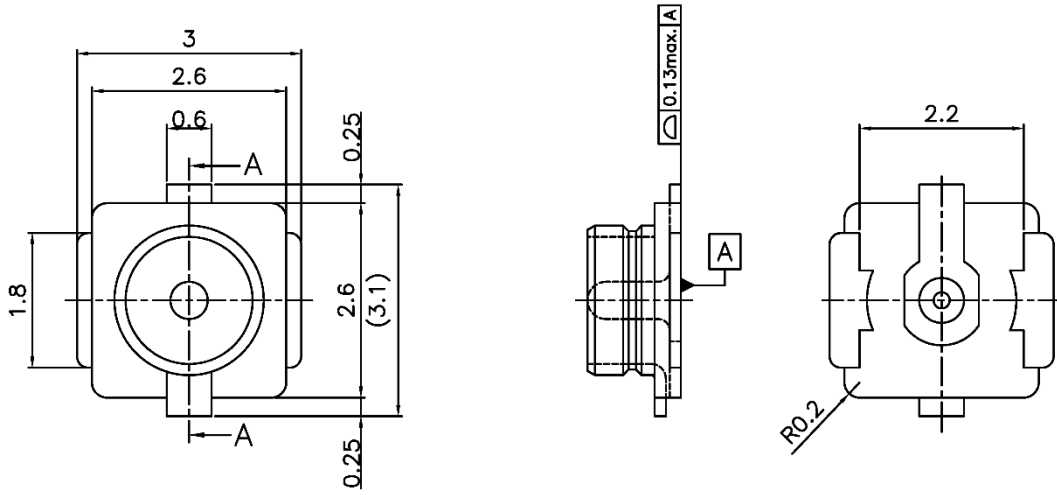

Unit: mm

## Pin Assignment

Pin#	Pin Name	Description	Pin#	Pin Name	Description
1	WAKE_L(NA)	Output and open Drain active Low signal. This signal is used to request that the system return from a sleep /suspended state to service a function initiated wake event.	2	+3.3V	+3.3V
3	No Connection	-	4	GND	GND
5	No Connection	-	6	No Connection	-
7	CLKREQ_L	Output for reference clock request signal	8	No Connection	-
9	GND	GND	10	No Connection	-
11	REFCLK-	Input signal for PCI Express differential reference clock (100 MHz)	12	No Connection	-
13	REFCLK+	Input signal for PCI Express differential reference clock (100 MHz)	14	No Connection	-
15	GND	GND	16	No Connection	-
17	No Connection	-	18	GND	GND
19	No Connection	-	20	W_DISABLE_L (OPT)	Input and active low signal. This signal is used by the system to disable radio operation on add-in cards that implement radio frequency applications. When implemented, this signal requires a pull-up resistor on the card
21	GND	GND	22	PERST_L	Input signal for functional reset to the card
23	PERn0	PCI Express x1 data interface: one differential receive pair	24	+3.3V	+3.3V

Pin#	Pin Name	Description	Pin#	Pin Name	Description
25	PERp0	PCI Express x1 data interface: one differential receive pair	26	GND	GND
27	GND	GND	28	No Connection	-
29	GND	GND	30	No Connection	-
31	PETn0	PCI Express x1 data interface: one differential transmit pair	32	No Connection	-
33	PETp0	PCI Express x1 data interface: one differential transmit pair	34	GND	GND
35	GND	GND	36	No Connection	-
37	GND	GND	38	No Connection	-
39	No Connection	-	40	GND	GND
41	No Connection	-	42	No Connection	-
43	GND	GND	44	LED_WLAN_L (OPT)	Output and open drain active low signal. This signal is used to allow the PCI Express Mini Card add-in card to provide status indicators via LED devices that will be provided by the system
45	No Connection	-	46	No Connection	-
47	No Connection	-	48	No Connection	-
49	No Connection	-	50	GND	GND
51	No Connection	-	52	+3.3V	+3.3V

\* **NA: No active**

\* **OPT: Optional**

(Depends on S/W and H/W design of the module and customer platform main board, functionalities of end devices and drivers.)

## Certification

### Dipole Ant.

 FCC

 IC

 NCC

 CE (RED EN 300 328 V2.2.2 / EN 301 893 V2.1.1)

 MIC

 ASNZS

## Ordering Information

Product Name	Part Number	Description
WPEQ-256ACN	R9701890025	802.11ac/b/g/n Mini PCIe Module(2T2R)

## Optional Accessory

Product Name	Part Number	Description
AD-300N	R3410110219	Antenna Dual -Band 2.4GHz/5GHz 3dBi/5dBi Omnidirectional RP-SMA PLUG(BSMA)
AD-301N	R3410110220	Dipole Antenna, 2.4G/5G 4.4dbi/5dbi RP-SMA(M) connector
AD-302N	R3410110221	Dipole Antenna, 3dBi/2dBi 2.4G/5GHz, RP-SMA(M) connector
AD-303N	R3410110222	Dipole Antenna, 3dBi/3dBi 2.4G/5GHz, RP-SMA(M) connector
AD-305N	R3410110223	Dipole Antenna, 5dBi/5dBi 2.4G/5GHz, RP-SMA(M) connector
AD-103AG	R3410110203	Antenna Dual-Band 2.4GHz/5GHz, 2dBi Omnidirectional RP-SMA(M)
CBIRF-ME150	R3470300023	I-PEX/MHF1 to RP-SMA Female; L:150mm; Coaxial 1.37 Black
CBIRF-ME250	R3470300024	I-PEX/MHF1 to RP-SMA Female; L:250mm; Coaxial 1.37 Black