

WPEQ-268AXI(BT)

WiFi 6/6E 2x2 MU-MIMO

802.11ax/ac/a/b/g/n Tri-band

2.4GHz/5GHz/6GHz



Industrial-Grade, 2T2R Wi-Fi+BT 5.2 Half Mini PCIe Module

Industrial-Grade Wi-Fi +BT Combo Solution Mini PCIe Module

WPEQ-268AXI(BT), first Qualcomm based WiFi-6E (802.11ax) mini PCIe module, running PCIe (Wifi) and USB (Bluetooth), supports DBDC (Dual-band, Dual-concurrent) mode, but with Tri-band capability (2.4GHz, 5GHz, and 6GHz). WPEQ-268AXI(BT) is able to concurrently run 2.4GHz with 5GHz, or 6GHz, and support full IEEE802.11 ax/ac/a/b/g/n protocol, up to 160MHz mode.

WPEQ-268AXI(BT) designed with 2 spatial streams (2T2R, or 2x2) in MU-MIMO mode. With a standard mini PCIe formfactor, WPEQ-268AXI(BT) can accommodate to all existing platform that has mini PCIe Adaptor pre-integrated, no extra work with platform design.

Software wise WPEQ-268AXI(BT) support Windows, with Linux (Open Source) in the near future. The module is capable to run on both x86 platform and ARM based platform, and supports STA mode and Soft AP Mode*, recommend to run on application includes: digital signage/POS, rugged computer / tablets, fanless automation PC and other industrial environment applications that requires high speed data transmission.

Embedded Application

Applications include IPC/ Advertising machine/ OTT/ IPTV/ DVB/ STB / DV/ Mini Driving Recorder/ Intelligent Projector Pico/ VR/ AR terminal/ POS machine/ Vehicle mounted front/ Rear Terminal UAV/ Robot/ Intelligent Gateway/ Smart city and other electronic products.

Key Feature

- Compliant with IEEE 802.11 ax/ac/a/b/g/n
- Supports 2x2 Multi-User Multiple-Input Multiple-Output (MU-MIMO)
- Dual Band Simultaneous (DBS), up to 3.6 Gbps data rate (2x2+2x2 11ax DBS)
- Tri-band 2.4 GHz/5 GHz/6 GHz support
- 20 MHz/40 MHz channel bandwidth for 2.4 GHz and 20 MHz/40 MHz/80 MHz/160 MHz channel bandwidth for 5 GHz/6 GHz

Specification

Standards	IEEE 802.11ax/ac/a/b/g/n (2T2R) Bluetooth V5.2, V5.1, V5.0, V4.2, V4.1, V4.0LE, V3.0, V2.1+EDR
Chipset	Qualcomm Atheros WCN6856
Data Rate	802.11b: 11Mbps 802.11a/g: 54Mbps 802.11n: MCS0~15 802.11ac: MCS0~9 802.11ax: MCS0~13 Bluetooth: 1 Mbps, 2Mbps and Up to 3Mbps
Operating Frequency	IEEE 802.11ax/ac/a/b/g/n ISM Band, 2.412GHz~2.484GHz, 5.150GHz~5.850GHz ,5.925~7.125GHz *Subject to local regulations
Interface	WLAN: PCIe Bluetooth: USB
Form Factor	Half Mini PCI-e
Antenna	2 x IPEX MHF1 connectors (Ant 1 for WLAN/BT, Ant 2 for WLAN)
Modulation	Wi-Fi: 802.11b: DSSS (DBPSK, DQPSK, CCK) 802.11g: OFDM (BPSK, QPSK, 16-QAM, 64-QAM) 802.11n: OFDM (BPSK, QPSK, 16-QAM, 64-QAM) 802.11a: OFDM (BPSK, QPSK, 16-QAM, 64-QAM) 802.11ac: OFDM (BPSK, QPSK, 16-QAM, 64-QAM, 256-QAM) 802.11ax:OFDMA (BPSK, QPSK, 16-QAM, 64-QAM, 256-QAM, 1024-QAM, 2048QAM,4096QAM) BT: Header: GFSK Payload 2M: $\pi/4$ -DQPSK Payload 3M: 8-DPSK
Power Consumption	TX mode: 632 mA (Average) RX mode: 378 mA (Average)
Operating Voltage	DC 3.3V
Operating Temperature Range	-40°~+85°C (Operating)
Storage Temperature Range	-45°C~90°C

Humidity (Non-Condensing)	5%~90% (Operating) 5%~90% (Storing)
Dimension L x W x H (in mm)	29.85mmx 26.65mmx 4.20mm
Weight (g)	3.2g
Driver Support	Windows 10,11 / Linux (Open Source)
Security	64/128-bits WEP, WPA, WPA2, WPA3, 802.1x

OUTPUT POWER & SENSITIVITY
802.11b

Data Rate	Tx \pm 2dBm	Rx Sensitivity
11Mbps	18 dBm	\leq -90 dBm

802.11g

Data Rate	Tx \pm 2dBm	Rx Sensitivity
54Mbps	17.5 dBm	\leq -74 dBm

802.11n / 2.4GHz

HT20	Data Rate	Tx \pm 2dBm (1TX)	Tx \pm 2dBm (2TX)	Rx Sensitivity
	MCS7	16dBm	19 dBm	\leq -73 dBm
HT40	MCS7	16dBm	19 dBm	\leq -71 dBm

802.11a

Data Rate	Tx \pm 2dBm	Rx Sensitivity
54Mbps	16.5 dBm	\leq -77 dBm

802.11n / 5GHz

HT20	Data Rate	Tx \pm 2.5dBm (1TX)	Tx \pm 2.5dBm (2TX)	Rx Sensitivity
	MCS7	16 dBm	19 dBm	\leq -76 dBm
HT40	MCS7	15.5 dBm	18.5 dBm	\leq -73 dBm

802.11ac

VHT80	Data Rate	Tx \pm 2.5dBm (1TX)	Tx \pm 2.5dBm (2TX)	Rx Sensitivity
	MCS9	15 dBm	18 dBm	\leq -62 dBm
VHT160	MCS9	14 dBm	17 dBm	\leq -58 dBm

802.11ax / 2.4 GHz

HE40	Data Rate	Tx \pm 2dBm (1TX)	Tx \pm 2dBm (2TX)	Rx Sensitivity
	MCS11	13 dBm	16 dBm	\leq -57 dBm

802.11ax / 5GHz				
	Data Rate	Tx \pm 2.5dBm (1TX)	Tx \pm 2.5dBm (2TX)	Rx Sensitivity
HE20	MCS11	12.5 dBm	15.5 dBm	\leq -64.5 dBm
	MCS11	12 dBm	15 dBm	\leq -63.5 dBm
HE40	MCS11	10 dBm	13dBm	\leq -59 dBm
HE160	MCS11	10 dBm	13dBm	\leq -56.5 dBm

802.11ax / 6GHz				
	Data Rate	Tx \pm 2.5dBm (1TX)	Tx \pm 2.5dBm (2TX)	Rx Sensitivity
HE20	MCS11	10.5 dBm	13.5 dBm	\leq -63 dBm
	MCS11	10 dBm	13 dBm	\leq -61 dBm
HE40	MCS11	9.5 dBm	12.5 dBm	\leq -58 dBm
HE160	MCS11	8 dBm	11 dBm	\leq -55 dBm

Bluetooth		
Data Rate	Tx \pm 2dBm (Class 1 Device)	Rx Sensitivity
3Mbps	$0 \leq$ Output Power \leq 14 dBm	<0.1% BR, BER at -70dBm

Block Diagram

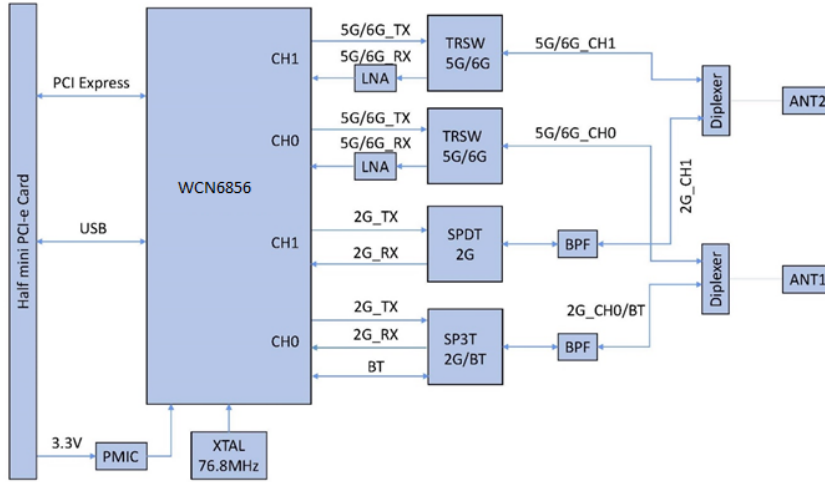

Mechanical Dimension (mm)

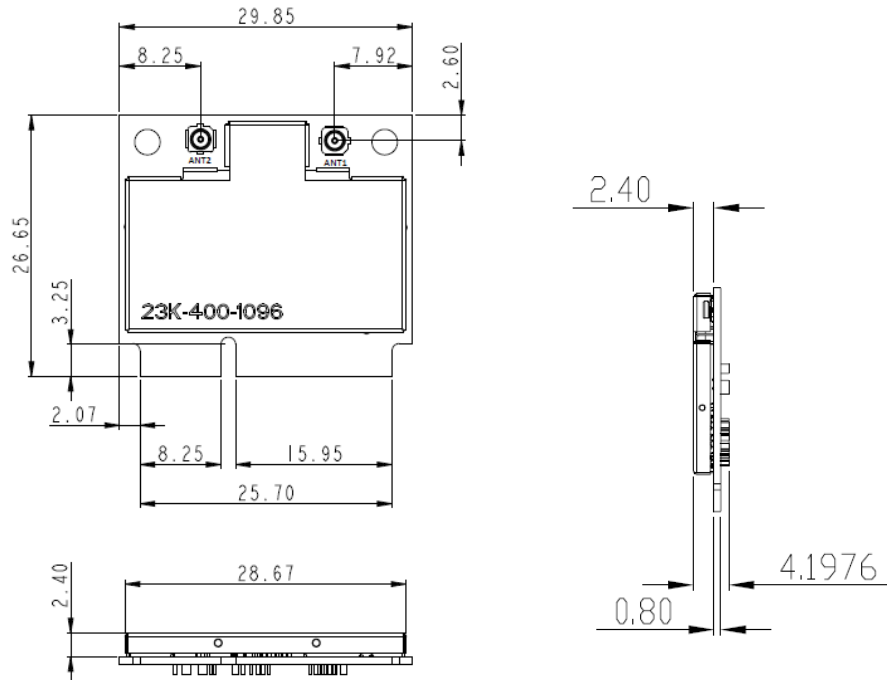

MHF1 connector spec.

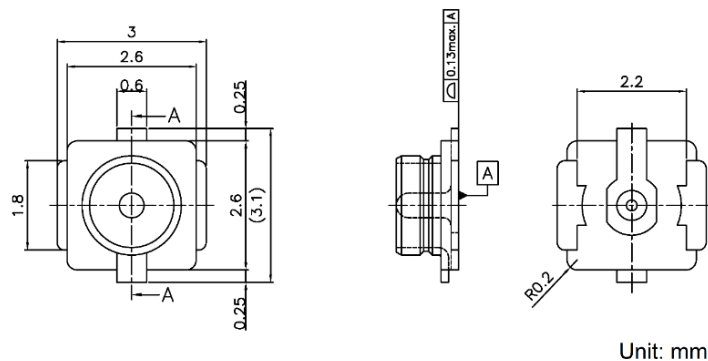

Unit: mm

Pin Assignment

The following section illustrate signal pin-outs for the module connector.

TOP			
Pin#	Pin Name	Type	Description
1	WAKE#	I/O	Open Drain active Low signal. When the add-in card supports wakeup, this signal is used by the add-in card to request that the system return from a sleep/suspended state to service a function initiated wake event. When the add-in card supports the OBFF mechanism, this signal is used by the system to indicate OBFF or CPU Active State transitions.
3	COEX1	DNC	Do Not Connect
5	COEX2	DNC	Do Not Connect
7	CLKREQ#	I/O	Reference clock request signal. Also used by L1 PM Substates
9	GND	G	Ground connections
11	REFCLK-	I	PCIe differential clock input- Negative
13	REFCLK+	I	PCIe differential clock input- Positive
15	GND	G	Ground connections
17	UIM_IC_DM	NC	No Connection
19	UIM_IC_DP	NC	No Connection
21	GND	G	Ground connections
23	PETn0	O	PCIe Transmit data-Negative
25	PETp0	O	PCIe Transmit data-Positive
27	GND	G	Ground connections
29	GND	G	Ground connections
31	PERn0	I	PCIe receive data-Negative
33	PERp0	I	PCIe receive data-Positive
35	GND	G	Ground connections
37	GND	G	Ground connections
39	+3.3Vaux	P	VDD system power supply input
41	+3.3Vaux	P	VDD system power supply input
43	GND	G	Ground connections
45	ANTCTRL2	NC	No Connection
47	ANTCTRL3	NC	No Connection
49	Reserved	NC	No Connection
51	W_DISABLE2#	I	Active low signals. These signals are used by the system to disable radio operation on add-in cards that implement radio frequency applications. When implemented, these signals require a pull-up resistor on the card.

The following section illustrate signal pin-outs for the module connector.

BOTTOM			
Pin#	Pin Name	Type	Description
2	+3.3Vaux	P	VDD system power supply input
4	GND	G	Ground connections
6	1.5V/COEX3	NC	No Connection
8	UIM_PWR	NC	No Connection
10	UIM_DATA	NC	No Connection
12	UIM_CLK	NC	No Connection
14	UIM_RESET	NC	No Connection
16	UIM_SPU	NC	No Connection
18	GND	G	Ground connections
20	W_DISABLE1#	I	Active low signals. These signals are used by the system to disable radio operation on add-in cards that implement radio frequency applications. When implemented, these signals require a pull-up resistor on the card.
22	PERST#	I	Functional reset to the card
24	+3.3Vaux	P	VDD system power supply input
26	GND	G	Ground connections
28	+1.5V/ ANTCTRL0	NC	No Connection
30	SMB_CLK	NC	No Connection
32	SMB_DATA	NC	No Connection
34	GND	G	Ground connections
36	USB_D-	I/O	USB serial differential data Negative
38	USB_D+	I/O	USB serial differential data Positive
40	GND	G	Ground connections
42	LED_WWAN#	NC	No Connection
44	LED_WLAN#	DNC	No Function
46	LED_WPAN#	NC	No Connection
48	+1.5V/ ANTCTRL1	NC	No Connection
50	GND	G	Ground connections
52	+3.3Vaux	P	VDD system power supply input

Note: Power (P), Ground (G), Open-Drain (OD), Input (I), Output (O), Do Not Connect (DNC), No Connection (NC)

Certification

Dipole Ant.

 FCC IC NCC CE (RED EN 300 328 V2.2.2 / EN 301 893 V2.1.1) MIC ASNZS

Ordering Information

Product Name	Part Number	Description
WPEQ-268AXI(BT)	R9701A90007	11ax/ac/a/b/g/n Industrial Grade 2T2R Wi-Fi+BT Min PCIe Module

Optional Accessory

Product Name	Part Number	Description
AD-501AX	R3410A10050	Dipole Antenna, 3.7dBi/5dBi/5dBi 2.4G/5G/6GHz, RP-SMA(M) connector
CBIRF-ME150	R3470300023	RF Cable, I-PEX/MHF1 to RP-SMA(F); L150mm; Coaxial 1.37 Black
CBIRF-ME250	R3470300024	RF Cable, I-PEX/MHF1 to RP-SMA Female; L:250mm; Coaxial 1.37 Black